

# Panorama Power MK2

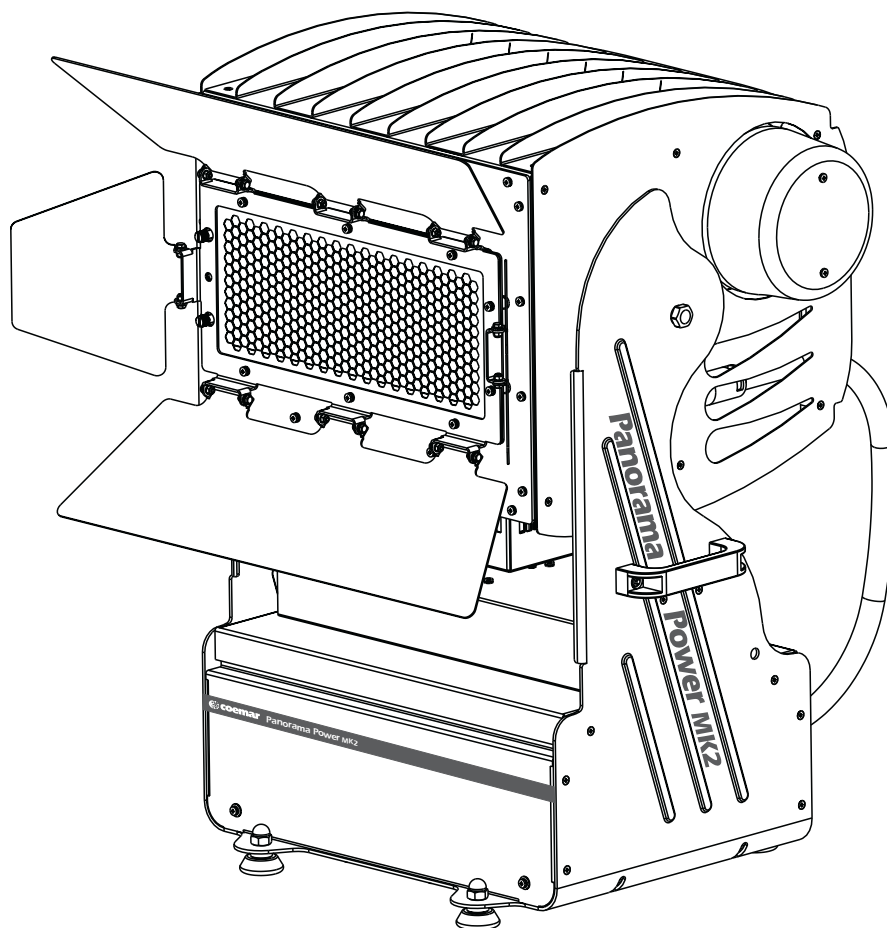

**manuale di istruzioni  
instructions manual**

Version 1.0

 **coemar**  
L I G H T E M O T I O N

# Panorama Power MK2

numero di serie/serial number

data di acquisto/date of purchase

fornitore/retailer

indirizzo/address

cap/città/suburb

provincia/capital city

stato/state

tel./fax/

Prendete nota, nello spazio apposito, dei dati relativi al modello e al rivenditore del vostro **Panorama Power MK2**: questi dati ci permetteranno di assistervi con la massima rapidità e precisione.

*Please note in the space provided above the relative service information of the model and the retailer from whom you purchased your **Panorama Power MK2**: this information will assist us in answering any technical enquiries with the utmost speed and accuracy.*

**ATTENZIONE:** la sicurezza dell'apparecchio è garantita solo con l'uso appropriato delle presenti istruzioni, pertanto è necessario conservarle.

**WARNING:** the security of the fixture is granted only if these instructions are strictly followed; therefore it is absolutely necessary to keep this manual.

# Index

<b>1. Packaging and transportation</b>	Pag. 4
1.1. Packaging	" 4
1.2. Transportation	" 4
<b>2. General information</b>	Pag. 4
2.1. Important safety information	" 4
2.2. Warranty conditions	" 5
2.3. CE norms	" 5
<b>3. Product specifications</b>	Pag. 5
3.1. Technical characteristics	" 5
3.2. Dimensions	" 5
3.3. Components	" 5
<b>4. Installation</b>	Pag. 6
4.1. Mechanical installation	" 6
4.2. Safety chains	" 7
4.3. Beam adjustment	" 7
4.4. Adjusting fan shrouds	" 8
4.5. Adjusting beam angles	" 8
4.6. Adjusting barndoors	" 9
<b>5. Powering up</b>	Pag. 10
5.1. Operating voltage and frequency	" 10
5.2. Altering the operating voltage and frequency	" 10
5.3. Mains connection	" 12
<b>6. DMX signal functions</b>	Pag. 13
6.1. Connecting DMX signal	" 13
6.2. Powering up	" 14
6.3. DMX addressing	" 14
6.4. DMX functions	" 15
<b>7. Display panel functions</b>	Pag. 16
7.1. Quick guide to menu navigation	" 16
7.2. Operating mode (MODE)	" 17
7.3. Measure and test (MEAS)	" 18
7.4. Function settings (FUNC)	" 19
7.5. Rapid scrolling	" 20
7.6. Connecting the DR1	" 20
<b>8. Automated functions</b>	Pag. 21
8.1. Signal connection for MASTER/SLAVE mode	" 21
8.2. MASTER/SLAVE mode	" 22
8.3. STAND ALONE mode	" 22
<b>9. Lamp installation and alignment</b>	Pag. 23
9.1. Lamp installation	" 23
9.2. Aligning the lamp in the optical path	" 25
<b>10. Thermal protection</b>	Pag. 25
<b>11. Maintenance</b>	Pag. 25
11.1. Periodic cleaning	" 25
11.2. Periodic maintenance	" 25
11.3. Fuse replacement	" 26
11.4. Electronic motor alignment	" 27
11.5. Resetting electronic counters	" 27
<b>12. Spare parts</b>	Pag. 28
<b>13. Patents</b>	Pag. 28
<b>14. Error messages</b>	Pag. 28
<b>15. Frequently asked questions</b>	Pag. 28

## English

Congratulations on having purchased a coemar product. You have assured yourself of a fixture of the highest quality, both in componentry and in the technology used. We renew our invitation to you to complete the service information on the previous page, to expedite any request for service information or spares (in case of problems encountered either during, or subsequent to, installation). This information will assist in providing prompt and accurate advice from your coemar service centre.

## 1. Packaging and transportation

Following the instructions and procedures outlined in this manual will ensure the maximum efficiency of this product for years to come.

### 1.1. Packaging

Open the packaging and ensure that no part of the equipment has suffered damage in transit. In case of damage to the equipment, contact your carrier immediately by telephone or fax, following this with formal notification in writing.

#### Packing list

Ensure the packaging contains:

- 1 **Panorama Power MK2**
- 1 **Instruction manual**
- 4 **Diffusion filters**

### 1.2. Transportation

The **Panorama Power MK2** should be transported in its original packaging or in an appropriate flight case.

## 2. General information

### 2.1. Important safety information

#### Fire prevention:

- 1. **Panorama Power MK2** utilises two **Philips MSR 575/2** or **575 MSD lamps**; the use of any alternative lamp is not recommended and will null and void the fixture's warranty.
- 2. Never locate the fixture on any flammable surface.
- 3. Minimum distance from flammable materials: 0,5 m.
- 4. Minimum distance from the closest illuminable surface: 2 m.
- 5. Replace any blown or damaged fuses only with those of identical values. Refer to the schematic diagram if there is any doubt.
- 6. Connect the projector to mains power via a thermal magnetic circuit breaker.

#### Preventing electric shock:

- 1. High voltage is present in the internals of the unit. Isolate the projector from mains supply prior to performing any function which involves touching the internals of the unit, including lamp replacement.
- 2. For mains connection, adhere strictly to the guidelines outlined in this manual.
- 3. The level of technology inherent in the **Panorama Power MK2** requires the use of specialised personnel for all service applications; refer all work to your authorised coemar service centre.
- 4. A good earth connection is essential for proper functioning of the projector.
- 5. Mains cables should not come into contact with other cables.
- 6. Do not operate the projector with wet hands.

#### Safety:

- 1. The projector should always be installed with bolts, clamps, and other fixings which are suitably rated to support the weight of the unit.
- 2. Always use a secondary safety chain of a suitable rating to sustain the weight of the unit in case of the failure of the primary fixing point.
- 3. Never install the fixture in an enclosed area lacking sufficient air flow; the ambient temperature should not exceed 35°C.
- 4. The external surface of the unit, at various points, may exceed 150°C. Never handle the unit until at least 10 minutes have elapsed since the lamp was turned off.
- 5. Always replace the lamp if any physical damage is evident.
- 6. A hot lamp may explode. Wait at least 10 minutes after the unit has been turned off prior to attempting to replace the lamp.
- 7. The projector contains electronic and electrical components which should under no circumstances be exposed to contact with water, oil or any other liquid. Failure to do so will compromise the proper functioning of the projector.

#### Protection against ultraviolet radiation:

- 1. Never turn on the lamp if any of the lenses, filters, or the aluminium housing is damaged; their respective functions will only operate efficiently if they are in perfect working order.
- 2. Never look directly into the lamp when it is operating.

#### Forced ventilation

You will note several air vents on the body of the projector. To avoid any problems associated with overheating, never obstruct any of these vents as this may seriously compromise the proper operation of the unit.

#### Protection rating against penetration by external agents:

- 1. The fixture has a protection rating of **IP 44**; this indicates that it is protected against showers and solid particles larger than 1 mm. Due to this rating, the fixture may be used in locations exposed to inclement weather.

## 2.2. Warranty conditions

1. The fixture is guaranteed for a period of 12 months from the date of purchase against manufacturing or materials defects
2. The warranty does not extend to damage caused by inappropriate usage or use by inexperienced operators.
3. The warranty is immediately void if the projector has been operated or dismantled by unauthorised personnel
4. The warranty does not extend to fixture replacement
5. The serial number of the projector is required for any advice or service fro your authorised coemar service centre.

## 2.3. CE norms

The projector meets or exceeds all applicable CE requirements.

## 3. Product specifications

### 3.1. Technical characteristics

Power:	208/230/240 Vac 50/60Hz
Nominal current:	7A
Maximum current:	9A
Power factor:	cos $\phi$ = 0,8
Lamp wattage:	2 x 575W MH
Maximum ambient temperature:	35°C / 95°F
Weight:	47.5 Kg / 104.5 lbs
Protection rating:	IP44

### 3.2. Dimensions

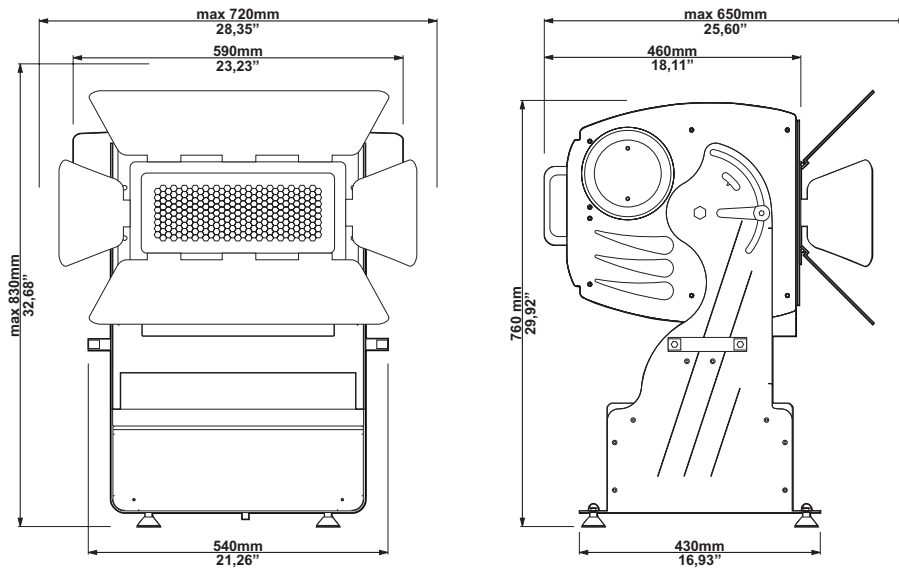

### 3.3. Components

The principle components of the **Panorama Power MK2** are shown below.

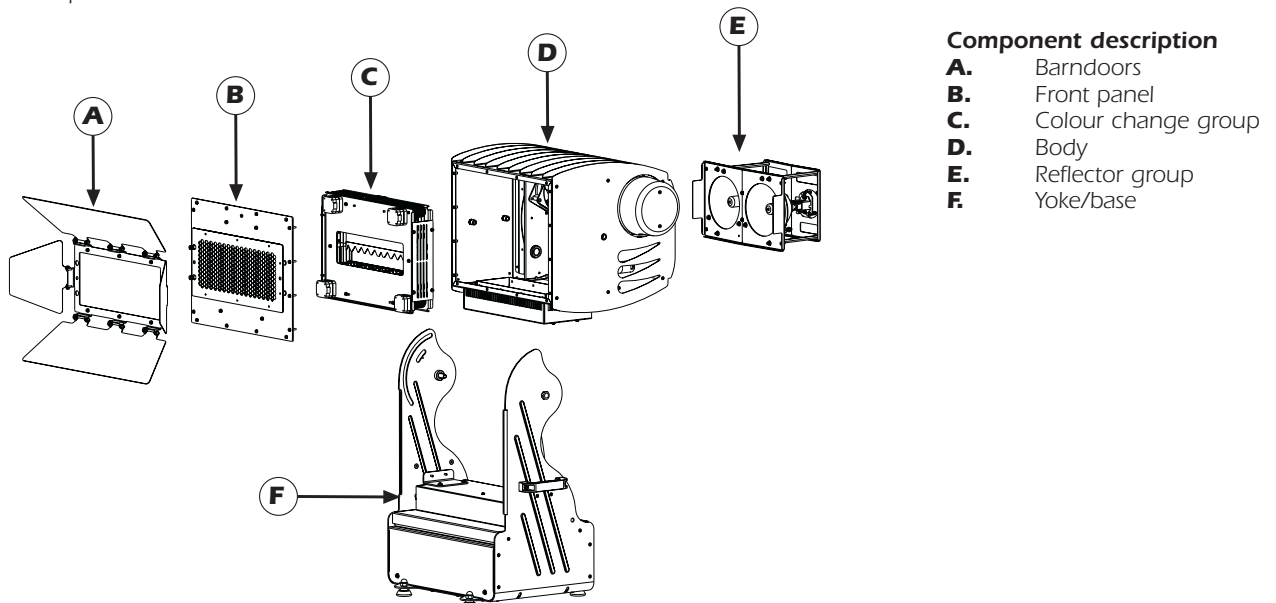

## 4. Installation

### 4.1. Mechanical installation

Due to its **IP44** protection rating, the **Panorama Power MK2** may be installed in both covered and weather-exposed locations. To ensure the protection rating is maintained, there are various installation restrictions with regard to position and tilt which must be adhered to as shown below:

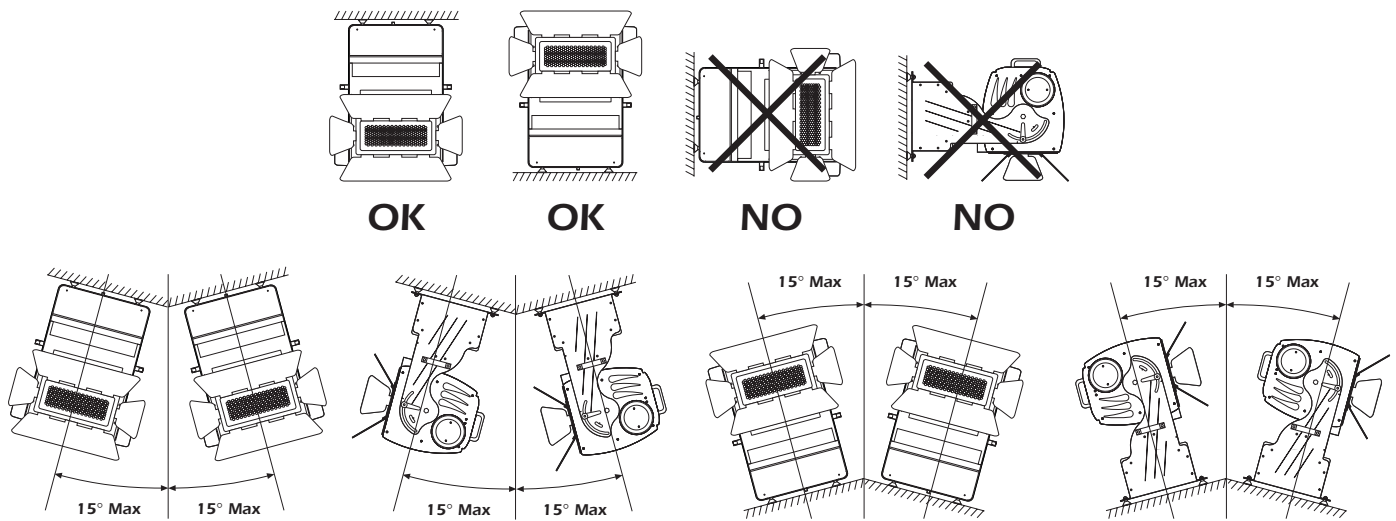

#### Permanent and temporary installation

So that it may be utilised in a variety of positions, the **Panorama Power MK2** is fitted with four rubber feet on its base. For more permanent and robust installations, you may remove the four feet and, utilise the four holes corresponding to those marked "A" in the following diagram.

When hanging the unit, we recommend the use of the optional support accessory (**cod. 9821**) to which clamps may be attached, as indicated at "B" in the diagram below. The support accessory allows the unit to be rotated through 360°.

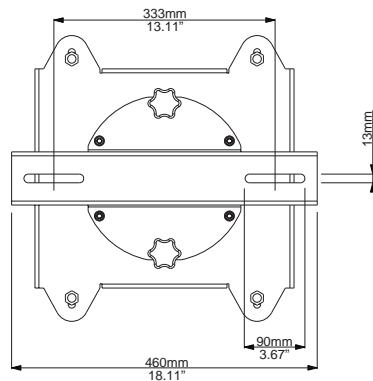
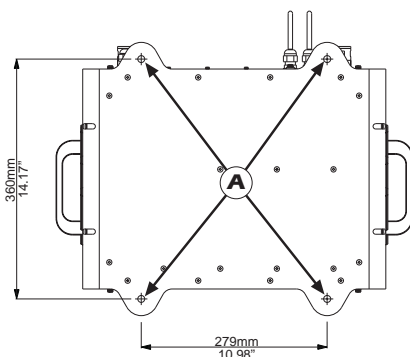

cod. 9821

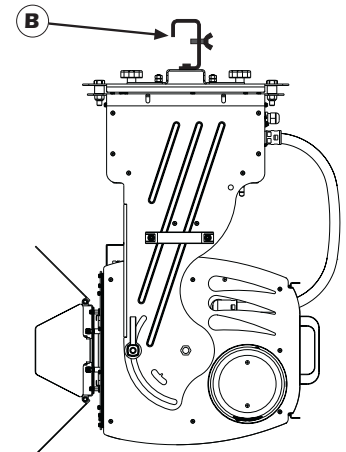

### ATTENTION!!

- Always ensure that the suspending structure and any hanging devices (clamps, bolts, etc) are rated suitably for the weight of the projector.
- Incorrect installation of the projector may cause substantial damage to the projector and will immediately void the fixture's warrant.

Do not install the projector in a location where it may be interfered with by people who are not familiar with the instructions contained in this manual.

## 4.2. Safety chain

If the **Panorama Power MK2** is affixed to a mobile structure the use of a safety chain designed to meet relevant safety standards is recommended. You may attach the safety chain "C" to the appropriate holes in the base of the **Panorama Power MK2** and to the suspending structure. Ensure that the safety chain being used is of a sufficient rating to hold the weight of the unit.

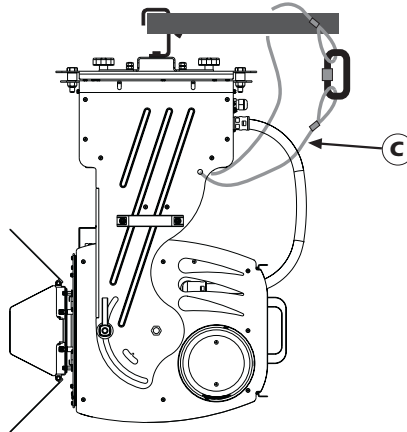

## 4.3. Beam adjustment

The angle of inclination of the **Panorama Power MK2** may be adjusted to ensure that the beam is pointing in the required direction. To alter the inclination, proceed with the following instructions.

1. Loosen the knobs "D" on the sides of the projector body.

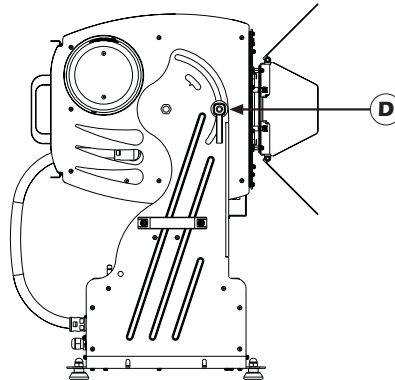

2. Adjust the inclination to suit (from +75° to -35°).

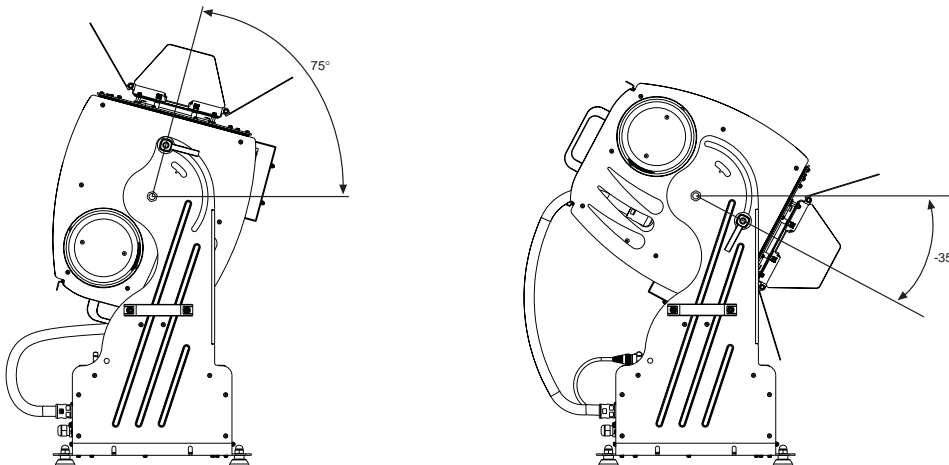

3. Retighten the knobs "D" on the side of the projector.



## English

### 4.4. Adjusting fan shrouds

After having adjusted the angle of inclination of the projector, you should follow these instructions to adjust the fan shrouds.



1. Loosen the two screws "E" which affix the shrouds to the sides of the projector.
2. Rotate the shroud "F" so that the intake port is pointing downwards. The shrouds may rotate through 150°. In applications where the projector is installed base up, completely remove the shrouds and refit them in an appropriate position.
3. Refasten the screws.

### ATTENTION!!

The process of adjusting the fan shroud position is imperative in ensuring that the projector receives sufficient air flow whilst maintaining its protection rating against penetration by both liquids and solids.

### 4.5. Adjusting beam angles

The **Panorama Power MK2** has 4 different diffusion filters available which can be used to alter the dimensions and shape of the beam output, thus making it suitable for a variety of situations.

Prior to undertaking the following procedure, ensure that either the projector is switched off or its dimmer is fully on.

### ATTENTION!!

Direct exposure to the output beam of the projector is not recommended.

The following pictures indicate the correct procedure for replacing the various diffusion filters.

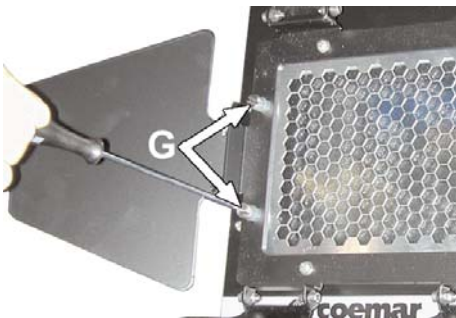

1. Using a suitable tool remove the two fasteners "G" which affix the filters.



2. Remove the filter "H" currently in position
3. Insert the appropriate filter to suit the beam dimensions you wish to achieve. Select from filter which alter different diffusion patterns and those which alter the vertical or horizontal output angles.
4. When you have inserted the appropriate filter, replace and secure the two fasteners previously removed.

A range of filters are available, as well as a diffusion kit (**cod. 9822**) to achieve maximum beam dimensions.



The table below illustrates the various beam angles which can be achieved by the **Panorama Power MK2** using the diffusion filters.

Filter type	Horizontal beam angle	Vertical beam angle
<b>1.</b> Diffusion filter (cod. <b>VT137</b> )	<b>39°</b>	<b>33°</b>
<b>2.</b> Medium diffusion filter (cod. <b>VT153</b> )	<b>43°</b>	<b>36°</b>
<b>3.</b> Horizontal diffusion filter (cod. <b>VT138</b> )	<b>74°</b>	<b>29°</b>
<b>4.</b> Vertical diffusion filter (cod. <b>VT139</b> )	<b>33°</b>	<b>67°</b>
<b>5.</b> Maximum diffusion kit (accessory cod. <b>9822</b> )	<b>116°</b>	<b>113°</b>

Additional adjustment of the projected beam angle may be achieved using the 4 barndoors.

#### **4.6. Adjusting barndoors**

The 4 leaf barndoors can be used to adjust and shape the projected beam angle of the **Panorama Power MK2** to further suit your needs. The following pictures indicate the procedure needed to adjust the barndoors.

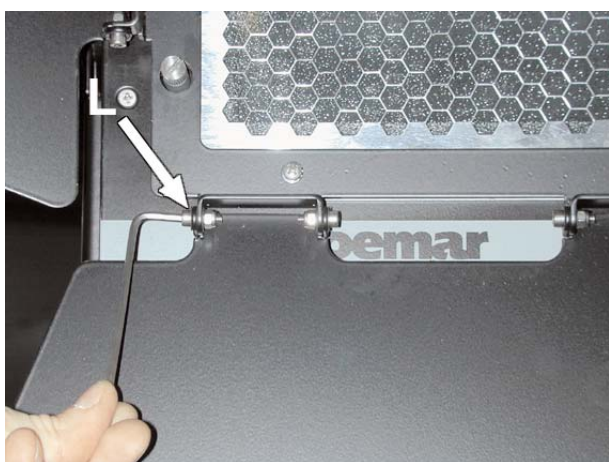

- 1.** Use a suitable tool to loosen the screws “L” which fasten the barndoors in position.

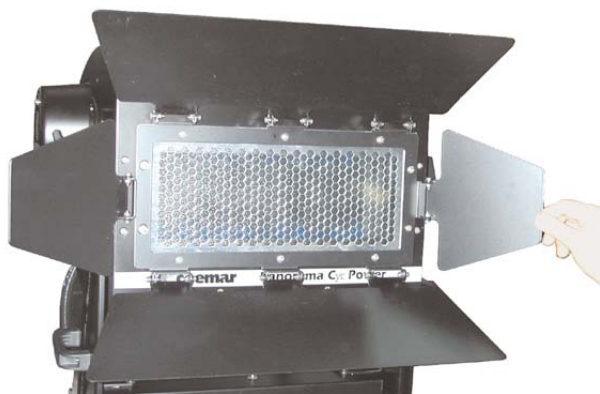

- 2.** Position the barndoors to achieve the required effect.

- 3.** After adjustment, ensure that the fasteners are securely tightened to ensure that the barndoors remain in the desired position.

## 5. Powering up

### 5.1. Operating voltage and frequency

The projector may operate at either 208, 230 or 240VAC at a frequency of either 50 or 60Hz. **Coemar** presets (barring specific requests) a voltage of 230v at a frequency of 50Hz.. The preset voltage is indicated on the base of the projector.

factory set main at:	
<input type="checkbox"/>	208V
<input checked="" type="checkbox"/>	230V
<input type="checkbox"/>	240V
<hr/>	
<input checked="" type="checkbox"/>	50Hz
<input type="checkbox"/>	60Hz

### 5.2. Altering the operating voltage and frequency (Reserved for technical personnel only)

If the factory preset operating voltage and frequency do not correspond to those in use in your country of operation, you may alter the settings as described in the following paragraphs.

#### ATTENTION!!

Incorrect selection of operating voltage and frequency will seriously compromise the functioning of the projector and will immediately void the warranty.

The required voltage and frequency adjustments must be made on both the ballast (lamp power) and the transformer (electronics power).

- Using an appropriate tool, remove the 8 screws "A" located on the side of the projector which affix the base cover.

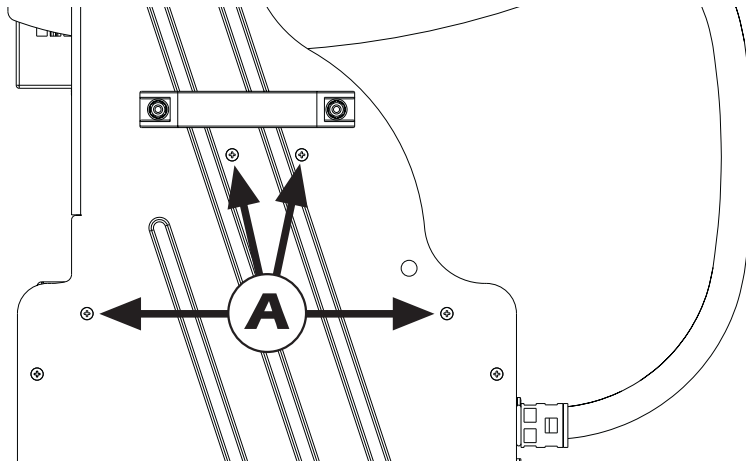

- Remove the base cover "B".

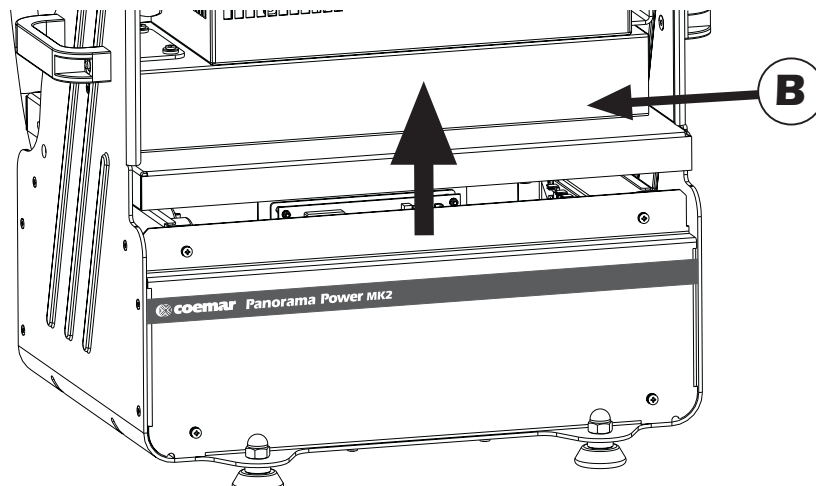

3. Locate the ballast inside the base.

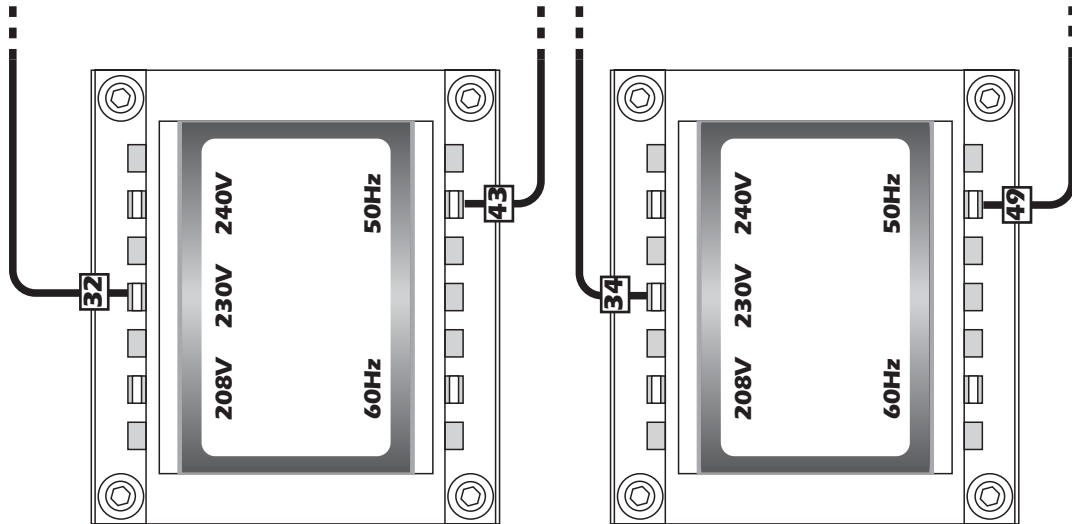

3. Cables 32 and 34 determine the operating voltage. Move them to the required voltage, 208, 230 or 240V on the ballast.  
 4. Cables 43 and 49 determine the operating frequency. Move them to the required frequency, 50 or 60Hz on the ballast. Refer to the stickers on the ballast to ensure correct selection is made.

5. Locate the transformer in the base.

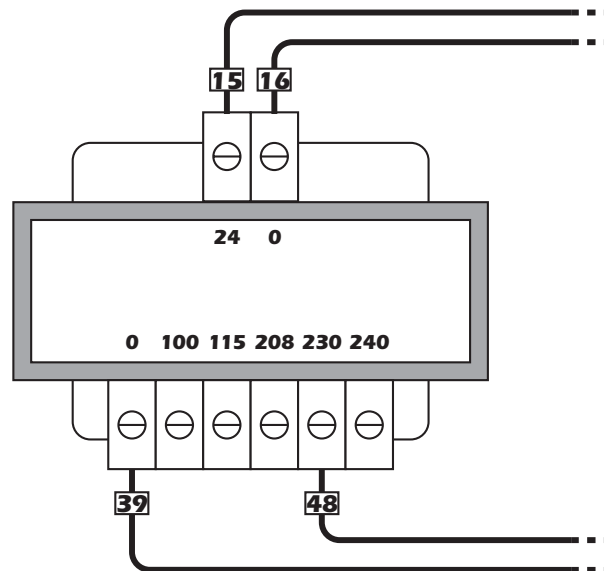

6. Select the voltage from 208, 230 or 240V by moving cable n° 48 to the required voltage. Refer to the sticker on the transformer to ensure correct selection is made.

### ATTENTION!!

Cable number 39 must not have its position altered under any circumstances.  
 The 100V and 115V voltages indicated on the transformer cannot be used.

7. When you have made the necessary changes, reposition and refasten the covers and screw as per their original position. To ensure that the fixtures protection rating is maintained, ensure that the cover is fitted and seated correctly and the screws tightened firmly, avoiding damage to the silicone seal.

## English

### 5.3. Mains connection

#### Mains cable characteristics

The mains cable provided is thermally resistant, complying to the most recent international standards. It meets or exceeds VDE and IEC norms, IEC 331, IEC 332 3C, CEI 20 35.

NB: In case of cable replacement, similar cable with comparable thermal resistant qualities must be used exclusively (cable 3x1.5  $\varnothing$  external 10 mm, rated 300/500V, tested to 2KV, operating temperature  $-40^{\circ}$   $+180^{\circ}$ , coemar cod. CV5309).

#### Mains connection

For connection purposes, ensure your plug is of a suitable rating to sustain the maximum current:

- 208/230/240V 9 amps constant current in normal operation

Locate the mains cable which exits the base of the unit and connect as shown below:

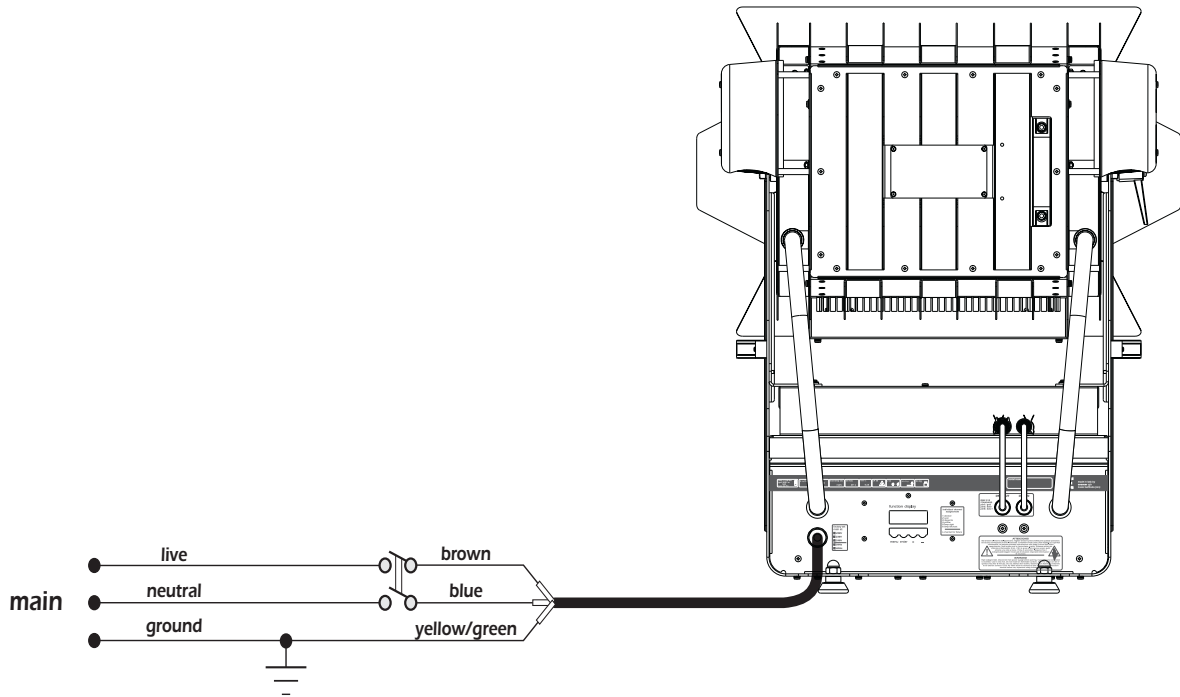

#### ATTENTION!!

- The use of a thermal magnetic circuit breaker is recommended for each projector. Strict adherence to all regulatory norms is highly recommended.
- Panorama Power MK2 should never be supplied mains power via a Dimmer; this is potentially dangerous.
- Prior to powering up the projector, ensure that the model in your possession correctly matches the mains supply available to you.
- A good earth connection is essential for the correct operation of the Panorama Power MK2. Never connect the projector to main power if the green/yellow earth cable is not correctly connected
- All cable and plug connections should be carried out by fully qualified and licenced personnel only.

## 6. DMX signal functions

Panorama Power MK2 may operate in two modes:

1. Using DMX 512 signal
2. In automatic "STAND ALONE" or "MASTER/SLAVE" (see section 8.0 Automated functions)

### 6.1. Connecting DMX signal

Control signal is digital and is transmitted via two pair screened  $\varnothing 0.5\text{mm}$  cable as per international standards for the transmission of DMX512 data. Connection is serial, utilising XLR 3 male and female sockets located on the base of the **Panorama Power MK2**. Coemar supplies XLR3 connectors with a IP67 protection rating. In order to preserve the protection rating of the **Panorama Power MK2**, use only similarly rated connectors for signal transmission and reception.

**Plug/socket connections for XLR3 connectors:**

Pin connections conform to the international standard as per the following table:

- pin 1 = GND
- pin 2 = data -
- pin 3 = data +

If using a controller which output signal via an XLR 5 (5 pin) socket, do not use pins 4 and 5, leave them unconnected.

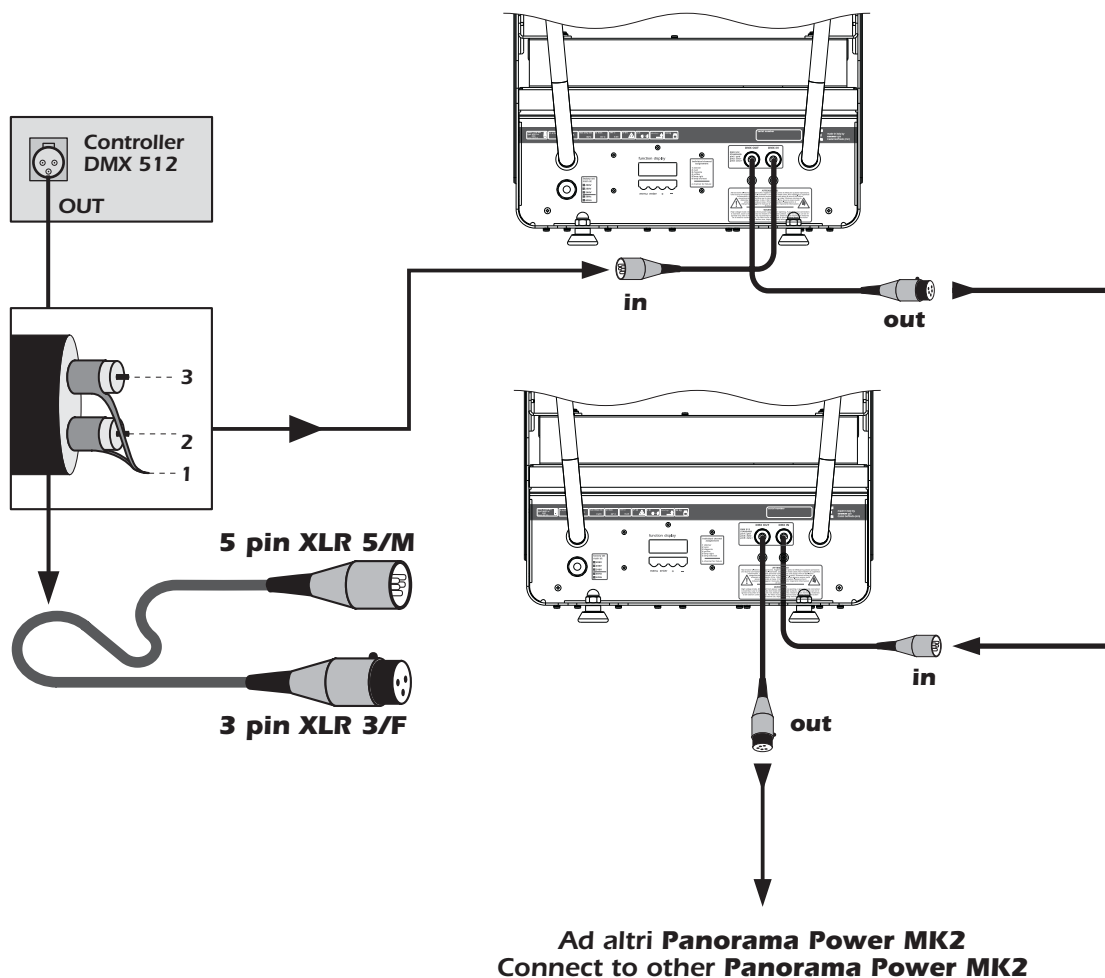

### ATTENTION!!

Ensure that all data conductors are isolated from one another and the metal housing of the connector.  
Pin number 1 should never be connected to the device's power supply.  
We recommend the use of an XLR3 DMX terminating connector

## English

### 6.2. Powering up

Panorama Power MK2 is supplied with a 4 leaf barndoor which is generally in the closed position when shipping.

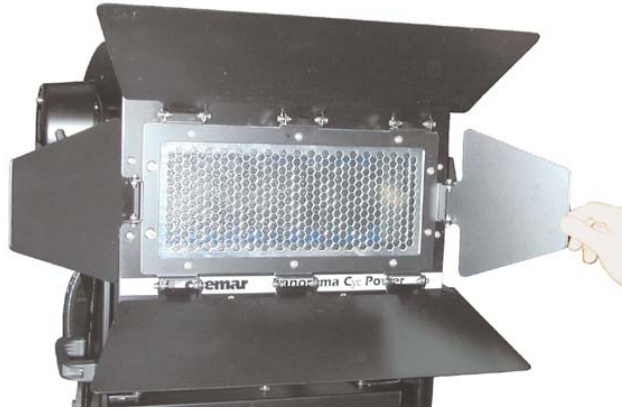

#### ATTENTION!!

The barndoors should always be in an open position prior to turning on the lamp. This will avoid the possibility of the lamp and projector being damaged through overheating.

After having completed all the operations discussed up to this point, turn on mains power to the fixture. The display will come on and show the software version currently installed in the internal microprocessor. For example, upon turning on power, the **Panorama Power MK2** may show:

V1.00 ( pcb software version )

The projector will perform a reset function on all the internal and external motors. This will last some few seconds, after which it will be subject to the external signal from the controller. The display will remain fixed on indicating correct **DMX 512** signal reception. **If the display flashed, there is no DMX signal being received.** Check your cabling and your controller.

### 6.3. DMX addressing

Each projector utilises **6** channels of **DMX 512** for complete control (for further information, see section **6.4 DMX functions**).

#### DMX addresses

Upon first powering up, the display will show **A001** indicating **DMX address 001**; a projector thus addressed will respond to commands on channel 1 to 6 from your DMX controller. A second unit should be addresses as A007, a third as A013 and so on until the final projector has been addressed.

#### Altering DMX addresses

1. Press the **+** or **-** buttons until the display shows the required **DMX** address. The characters in the display will flash to indicate that the selection is not yet stored in memory.
2. Press the **enter** button to confirm your selection. The display panel will cease to flash and the projector will now respond to the new **DMX 512** address.

#### function display

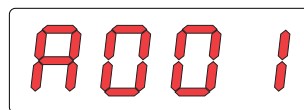

menu enter + -

**Important Note:** holding down the **+** or **-** buttons will cause the display to alter at an increased speed, allowing a faster selection to be made.

#### ATTENTION!!

If you alter the DMX with no DMX controller connected, the characters in the display panel will continue to flash even after you have pressed the ENTER button.

## 6.4. DMX functions

channel	function	type of control	effect	decimal	percentage
1	dimmer	step	closed	0 - 7	0% - 3%
		proportional	from close to open	8 - 255	3% - 100%
2	cyan	proportional	proportional cyan control from white to cyan	0 - 255	0% - 100%
3	magenta	proportional	proportional magenta control from white to magenta	0 - 255	0% - 100%
4	yellow	proportional	proportional yellow control from white to yellow	0 - 255	0% - 100%
5	right lamp on-off	step	park, no function	0 - 10	0% - 4%
			right lamp off	11 - 29	4% - 11%
			park, no function	30 - 140	12% - 55%
			right lamp on	141 - 255	55% - 100%
6	left lamp on-off and motors reset	step	park, no function	0 - 10	0% - 4%
			left lamp off	11 - 29	4% - 11%
			cmy reset (once only)	30 - 135	12% - 53%
			cmy and dimmer reset (once only)	136 - 170	53% - 67%
			park, no function	171 - 240	67% - 94%
			left lamp on	241 - 255	95% - 100%
<b>Note 1: back panel can inhibit lamp off function.</b>					
<b>Note 2: lamp on-off and motors reset functions has a delay time of 6 second to prevent accidental activation.</b>					
<b>Note 3: on/off lamp mode is not affected unless an opposite value is received.</b>					

To ignite the 2 lamps both channels number 5 and 6 must be set to a level between 141 and 255 and between 241 and 255 respectively. Lamps may also be ignited individually, using the display panel, as described in section **7.4 Function setting (FUNC)**.



## 7. Display panel functions

The display panel of the **Panorama Power MK2** shows all the functions available; it is possible to change some of those parameters and to add some functions.

Changing the preset settings made by coemar can vary the functions of the device so that it may not respond to a DMX 512 controller being used to control it. Carefully follow the instructions before applying any variations or selections.

**NOTE:** the symbol  shows which key has to be pushed to obtain the desired function.

### 7.1. Quick guide to menu navigation

For your convenience, the following is a guide to navigating the menu system of the projector.

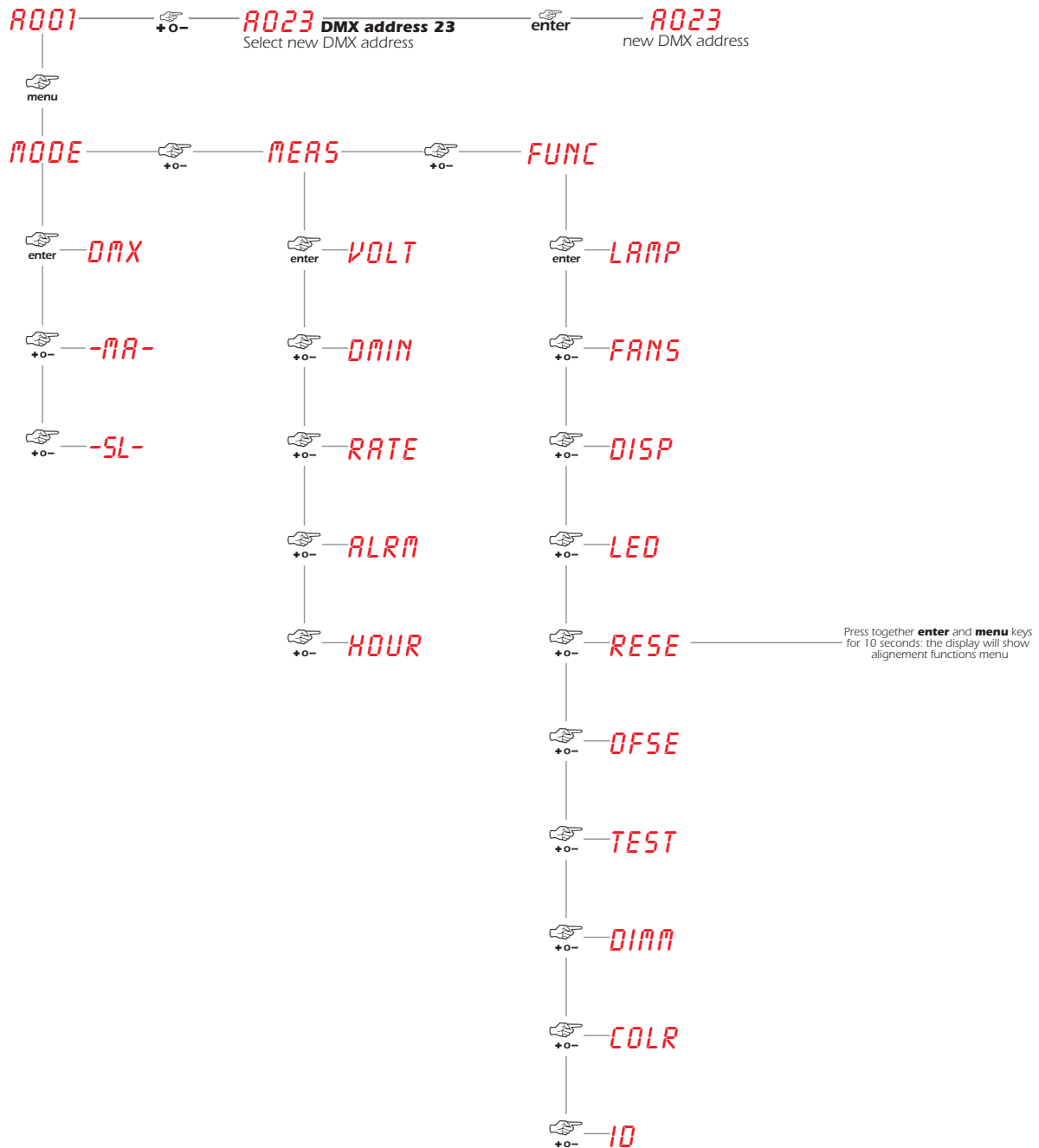

## 7.2. Operating mode (MODE)

By using the **Panorama Power MK2** display panel it is possible to alter the operating mode of the projector. The following diagram shows the menu navigation layout in **MODE**.

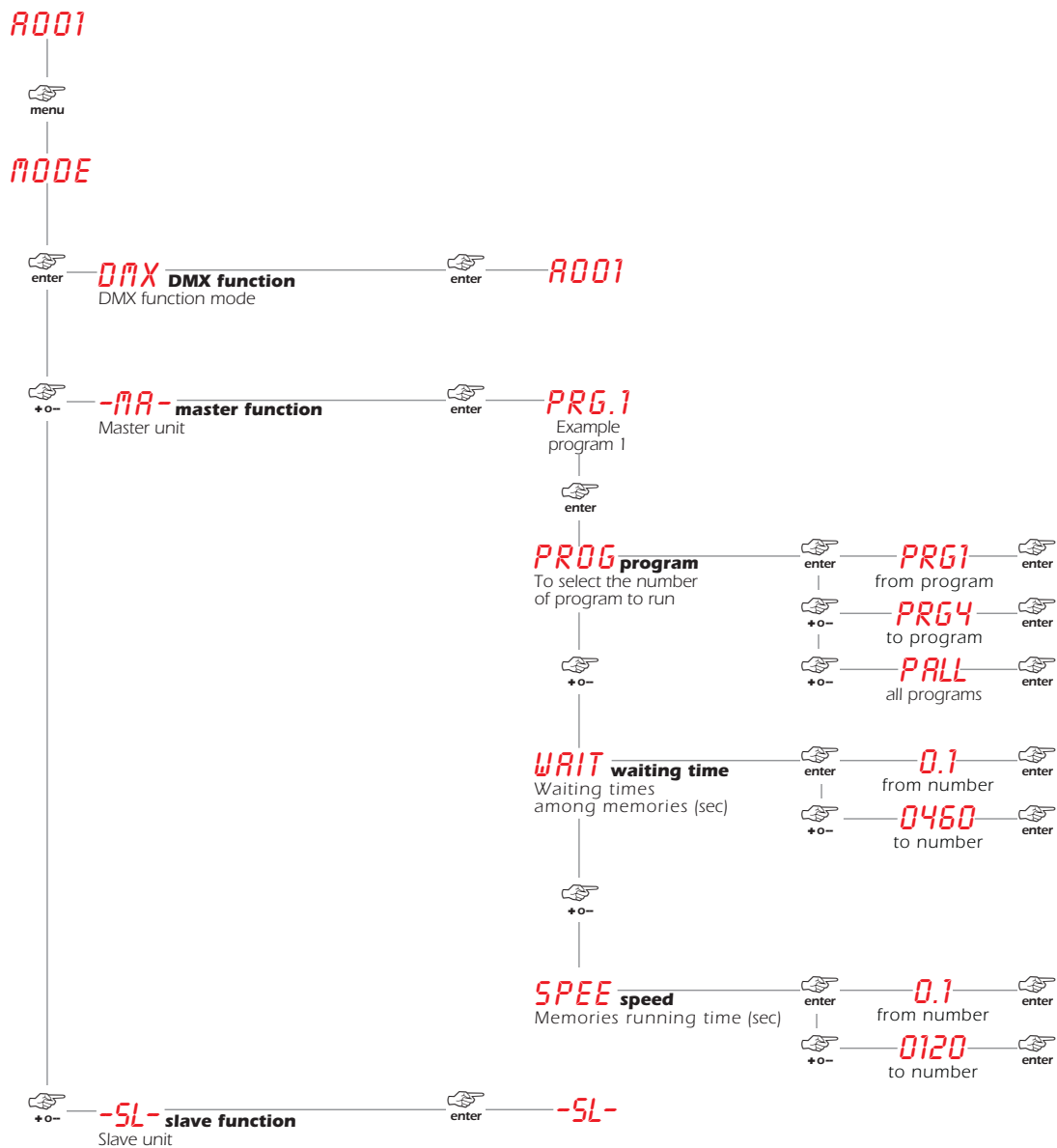

For a complete description of the fixture's automated MASTER/SLAVE or STAND ALONE functions, see section **8. Automated functions**.

### 7.3. Measure and test (MEAS)

The internal microprocessor of the **Panorama Power MK2** allows for several diagnostic and output parameters to be displayed. You may record, in this menu, determine the position in which the projector will come to rest when turned on with no dmx signal attached.

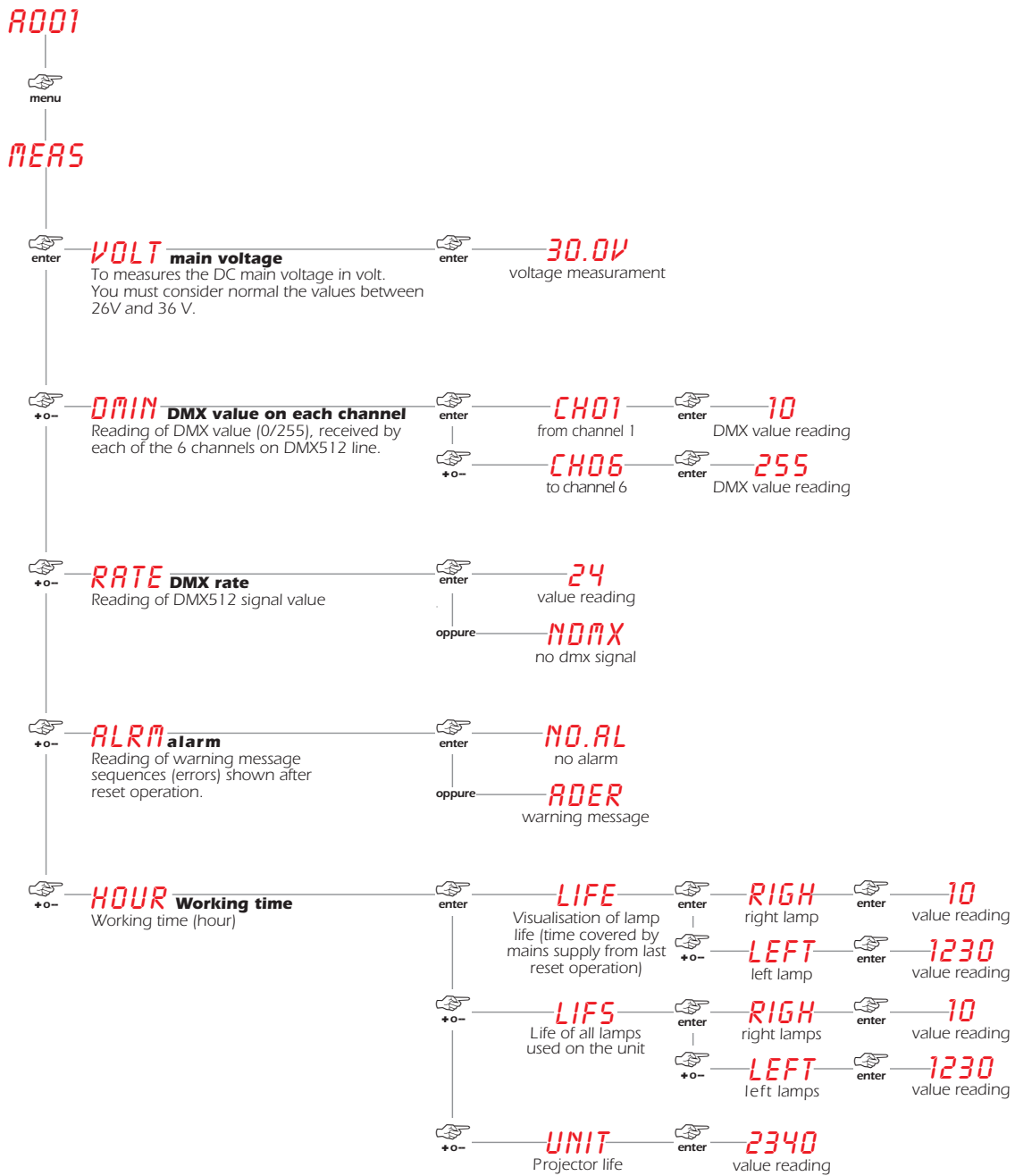

## 7.4. Function settings (FUNC)

The projector allows the altering of several functions and for selecting personalised settings.

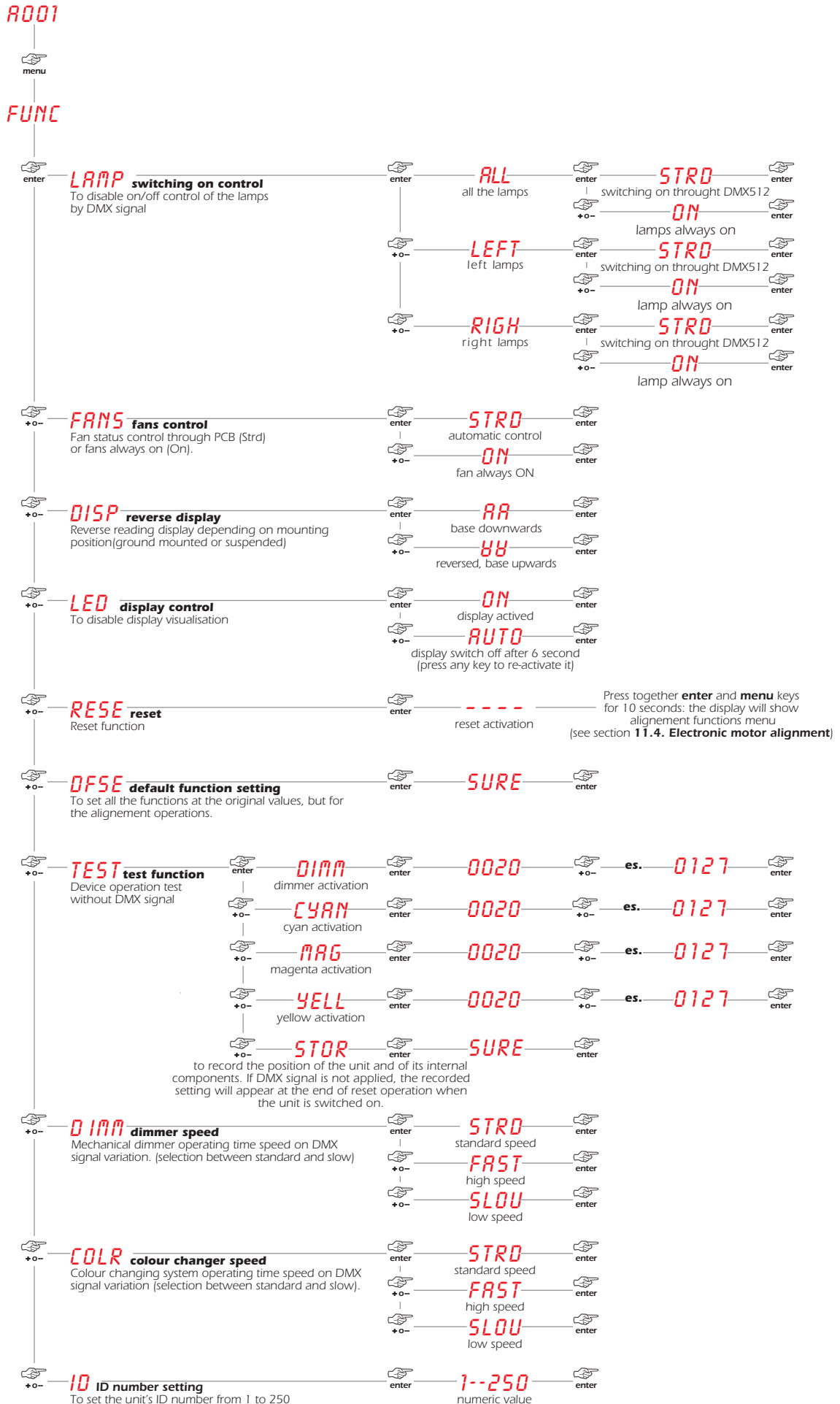

## English

### 7.5. Rapid scrolling

Via the **Panorama Power MK2** display it is possible to rapidly scroll through the various numbers displayed in the menu in the following manner:

1. Pressing the **+** or **-** buttons will cause the number to scroll more quickly.
2. Pressing and holding the **+** button and then the **-** button will cause the numbers to jump to the highest value.
3. Pressing and holding the **-** button and then the **+** button will cause the numbers to jump to the lowest value.

### 7.6. Connecting the DR1

All the functions available via the display menu are also available via the **DR1** (cod. **9703**).

The **DR1** is a remote device designed for technical users who need to perform tasks on the projectors whilst they may be located in inaccessible positions. It acts as a remote control.

The **DR1** eliminates the need for climbing up truss structures to gain direct physical access to the projector to alter such parameters as DMX address, reading outputs such as lamp life, setting master/slave configurations as well as all other functions available via the digital display unit on the projector.

In order to utilise the **DR1** remote device, you must first activate the identifying number **ID** of the projector, which must be unique in the particular DMX universe in which it is currently installed.

#### ATTENTION!!

- If you set a projector's identification number to "0" it will not be able to communicate with the DR1.
- Never assign the same ID to two or more projectors. This may jeopardise the functioning of the entire system. (The DR1 will show an error message).

The method for setting an identification number **ID** is shown below.

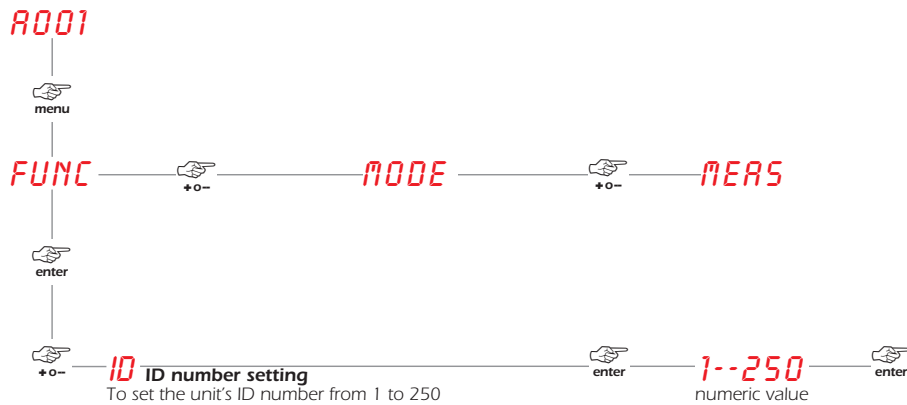

For further information, consult the **DR1 instruction manual**.

## 8. Automated functions

The **Panorama Power MK2** may operate without external DMX 512 signal. Using this function, it is possible to select the operating mode (**STAND ALONE** or **MASTER/SLAVE**), select the program to be executed and modify timing parameters. In this mode, DMX control is inhibited.

### 8.1. Signal connection for MASTER/SLAVE mode

In **MASTER/SLAVE** mode it is possible to have one unit designated as **MASTER** controlling a series of **Panorama Power MK2** designated as **SLAVE** units. Determining which **Panorama Power MK2** should be the **MASTER** unit is generally based only on the criterion of ease of access. The following diagrams and instructions indicate the manner of connection for units to be used in this mode.

Connect the projectors via the XLR3 sockets beginning with output of the **MASTER** unit to the input of the first **SLAVE**, the output of the first **SLAVE** to the input of the second and so on to a maximum of 10 projectors. **Coemar** supplies on the units XLR3 connectors with an IP67 protection rating; use only similarly rated connectors so as to preserve the IP protection rating of the **Panorama Power MK2**.

Should you wish to connect in excess of 10 units, we recommend the use of a suitable opto-isolated splitter and amplifier to retransmit the signal as required.

**Plug/socket connections for XLR3 connectors:**

Pin connections conform to the international standard as per the following table:

pin 1 = GND  
pin 2 = data -  
pin 3 = data +

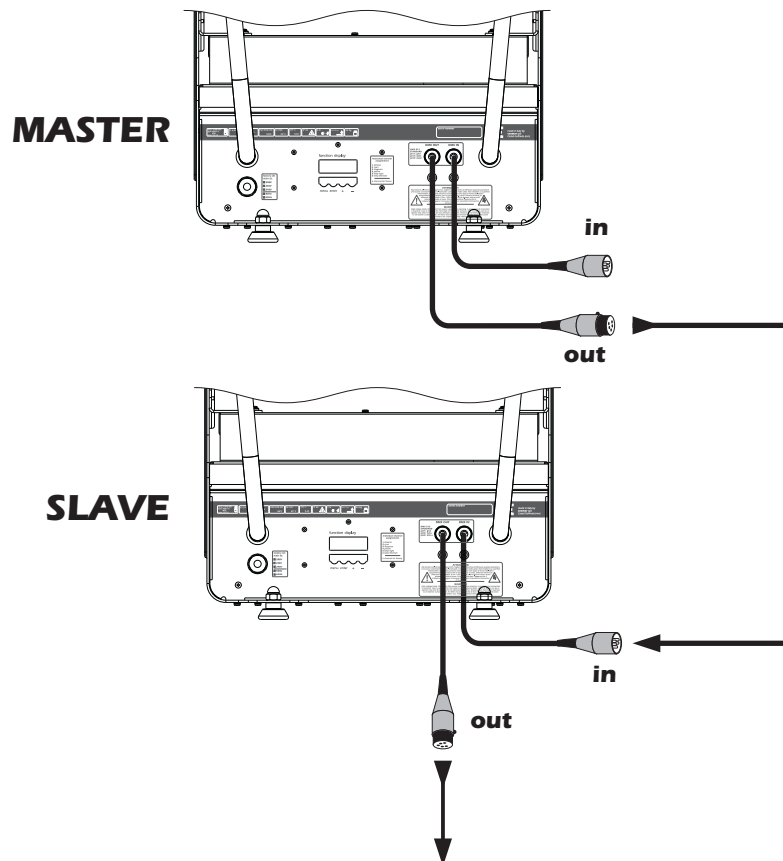

**Ad altri Panorama Power MK2 slave  
Connect to other Panorama Power MK2 slave**

### **ATTENTION!!**

Ensure that all data conductors are isolated from one another and the metal housing of the connector.  
Pin number 1 should never be connected to the device's power supply.

We recommend the use of an XLR3 DMX terminating connectors for any unconnected sockets (both the XLR3 input socket on the master, and the XLR3 output socket of the last slave).

The master/slave facility of the Panorama Power MK2 is not compatible with those of the Panorama Cyc Power.  
No external controller or device should be present in the master/slave daisy chain (eg DMX consoles) to ensure that no conflicting signal is present.

## English

### 8.2. MASTER/SLAVE mode

After having connected the projectors, as described in section **8.1 MASTER/SLAVE signal connection**, turn on power to the projectors. Settings are made via the 4 button display panel.

#### Setting up a "MASTER"

Only one projector may be set up as MASTER, the initial projector in the dmx daisy chain. Via the display panel, it is also possible various parameters such as program execution speed between steps (WAIT) and the speed of colour changes (SPEED).

To set up a projector as **MASTER**, follow these instructions:

1. Press the **menu** button
2. Press the **+** or **-** buttons until **MODE** shows in the display. Press the **enter** button.
3. Press the **+** or **-** buttons until **-MA-** shows in the display. Press the **enter** button.

The display will show **PRG.1** The projector is set to **MASTER** with program 1 running.

If you wish to select a different program:

4. Press the **enter** button. The display will show **PROG**. Press the enter button.
5. Press the **+** or **-** button to view the range of programs available. There are 4 preset programs as well as one named **PALL** runs all available programs in sequence. Select the program you wish to run and then press the enter button.

If you wish to alter the wait time between execution of steps in a program, complete the following instructions:

6. Press the **enter** button. The display will show **PROG**.
7. Press the **+** or **-** button until **WAIT** is shown in the display. Press the enter button.
8. Press the **+** or **-** button to select the wait time between steps then press the enter button.

If you wish to alter the speed of the colour changes:

9. Press the **enter** button. The display will show **PROG**.
10. Press the **+** or **-** button until **SPEE** is shown in the display. Press the enter button.
11. Press the **+** or **-** button to select the speed at which you wish to have the colour change occur then press the enter button.

To exit **MASTER** mode, press the menu button and via the **MODE** function, select a different mode.

#### Setting up a "SLAVE"

All projectors which are to be connected to your MASTER projector must be set to **SLAVE** mode. All cabling connecting the projectors should be set as described in section **8.1 Signal connection for MASTER/SLAVE mode**.

To set up a projector as a **SLAVE** carry out the following instructions:

1. Press the menu button.
2. Press the **+** or **-** buttons until **MODE** shows in the display. Press the **enter** button.
3. Press the **+** or **-** buttons until **-SL-** shows in the display. Press the **enter** button.

The display will show **-SL-**. The projector is now set to **SLAVE**.

To exit **SLAVE** mode, press the menu button and via the **MODE** function, select a different mode.

### 8.3. STAND ALONE mode

In **STAND ALONE** mode, the projector functions independently. It therefore requires no incoming DMX signal.

It is possible to alter various parameters such as program step execution speed (WAIT) and the speed of colour changes (SPEED).

#### **ATTENTION!!**

**To configure a projector as STAND ALONE, carry out the same procedure as that which configures a unit as a MASTER.**



## 9. Lamp installation and alignment

**Panorama Power MK2** utilises two **Philips 575/2 MSR** or **MSD 575** lamps of 575W with a GX 9,5 base . All lamps are available from your **Coemar** service centre.

Lamp	Philips 575 MSR/2	Philips 575 MSD
Coemar code	105245/2	105215
Power	575W	575W
Luminous flux	49.000 lm	43.000 lm
Colour temperature	7200° K	6000° K
Lamp base	GX 9,5	GX 9,5
Rated lamp life	1000 hours	3000 hours

The fixture's internal temperature can reach 250° C after 5 minutes, with a maximum peak of 350° C; ensure that the lamp is cold prior to attempting removal. The fixture should be allowed to stand and cool for 10 minutes prior to its removal. MSR/2 and MSD lamps are part of the mercury vapour family of discharge lamps and must be handled with great care. The lamp operates at high pressure, and the slight risk of explosion of the lamp exists if operated over its recommended life. We recommend, therefore, that the lamp be replaced within the manufacturer's specified lamp life.

### ATTENTION!!

Disconnct the unit from mains power prior to attempting lamp installation or replacement  
Make sure the projector is sufficiently cooled.

### 9.1. Lamp installation

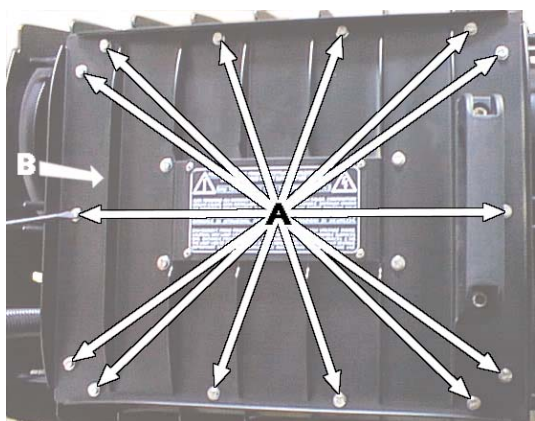

1. Use a suitable tool to remove the 14 screws "A" which affix the rear housing "B" of the projector.

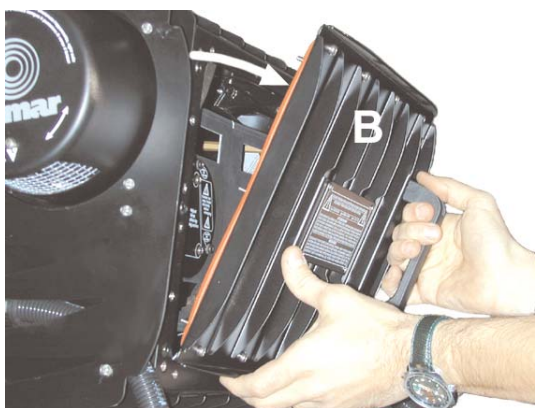

2. Remove the rear housing "B" of the projector with the handle provided.

## English



3. Locate the two lamp assemblies, right and left. Remove the two screws "C" which hold the assemblies in place.

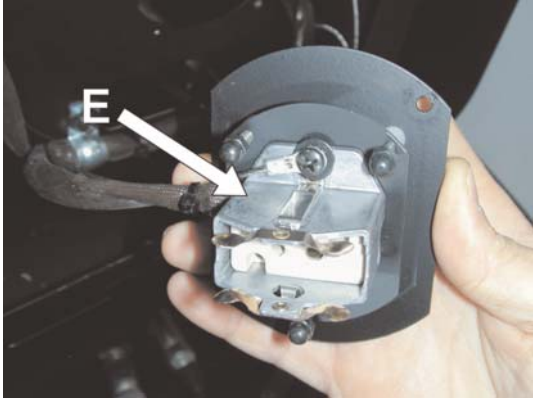

5. Locate the lampholder "E"



6. Insert the lamps. The lamp used is manufactured from quartz glass and should be handled with care; always adhere to the instructions supplied in the lamp's packaging. Never touch the glass directly, use the tissue provided in the lamp's packaging. The GX 9,5 lampbase is symmetrical in construction. **DO NOT USE UNDUE FORCE.** In case of difficulty, re-read the instructions and repeat the procedure.

7. Replace the lampholder assembly in its original position and refasten the screws which were previously removed.

8. Repeat the procedure for the second lamp.

### **ATTENTION!!**

Each time you change the lamp, we recommend the following be carried out:

- realign the lamp in the optical path to avoid overheating dichroics and dimmer.
- reset the lamp life counter (as described in section 11.5. Resetting the counter).

## 9.2. Aligning the lamp in the optical path

Aligning the lamp in the optical system is achieved via the 3 adjusters at the rear of the projector. This procedure should be undertaken to maximise output, properly align the lamp in the optical system and to avoid the possible overheating of the internal components due to the incorrect focusing of the beam onto components not intended to be exposed to this.

### Alignment procedure

Alignment is effected by the 3 adjusters **A**, **B** and **C** located on the lampholder assembly. The lamp should be on, black-out and dimmer fully open, and no colours selected. If the lamp is not correctly aligned, a hot-spot will be readily noticeable. Using the 3 adjusters in unison, you will need to bring the hot-spot to the centre of the beam (adjusters **B** and **C**) and then flatten the beam to maximum uniformity (adjuster **A**).

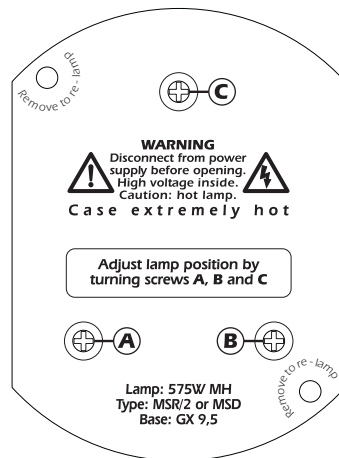

## 10. Thermal protection

A thermal sensor in the body of the **Panorama Power MK2** protects the unit against overheating. The thermal sensor operates by removing voltage to the lamp if the ambient temperature rises above a preset maximum due to either less than ideal air circulation around the fixture or in the event of cooling fan failure.

## 11. Maintenance

Whilst every possible precaution has been taken to ensure the trouble-free operation of your **Panorama Power MK2**, the following periodic maintenance is highly recommended.

### ATTENTION!!

**Always remove mains power and ensure the unit is sufficiently cooled prior to opening up the housing.**

### 11.1. Periodic cleaning

#### Protection lenses and reflectors

Even a fine layer of dust can reduce the lumious output substantially and alter beam characteristics. Regularly clean all diffusion filters on the projector. In order to do this correctly, it is necessary to remove the filters, as described in section **4.5 Adjusting beam angles**. Cleaning may be achieved using a soft cotton cloth dampened with a specialist lens cleaning solution. Reflectors may be cleaned using the same materials and should be carried out by qualified personnel.

### 11.2. Periodic maintenance

#### Lamp

The lamps should be replaced if there is any observable damage or deformation due to heat. This will avoid the danger of either lamp exploding. Access to the lamps is as described in section **9.1 Lamp installation and alignment**.

## English



### Fans and air passages

The fans and air passages must be cleaned approximately every 6 weeks; the period for this periodic cleaning will depend, of course, upon the conditions in which the projector is operating. Suitable instruments for performing this type of maintenance are a brush and a common vacuum cleaner or an air compressor.

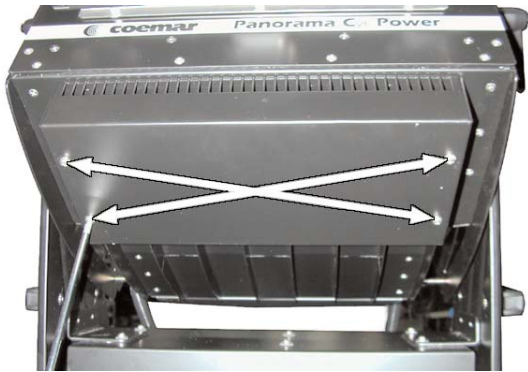

### Filters and air intakes

Air filters and intakes should be cleaned every month to maintain optimum operation of the cooling system. The period for this periodic cleaning will depend, of course, upon the conditions in which the projector is operating. Remove the four screws which hold the filters in place on the rear of the projector body. Clean using an air compressor and, if necessary, a liquid detergent solution.

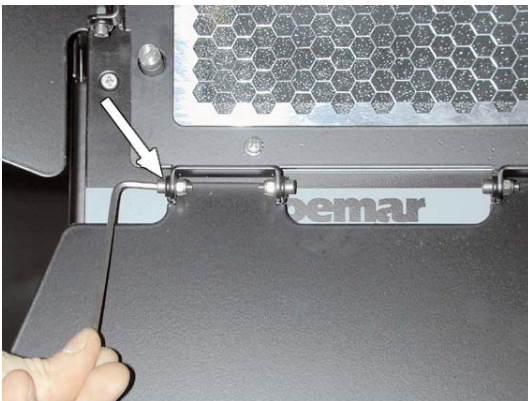

### Mechanicals

Periodically check all mechanical devices for wear and tear; gears, guides, belts, etc., replacing them if necessary. Periodically check the lubrication of all components, particularly the parts subject to high temperatures. If necessary, lubricate with suitable lubricant, available from your Coemar distributor. Check that the bolts which affix the barndoors are firmly fastened.

### Electrical components

Check all electrical components for correct earthing and proper attachment of all connectors, refastening if necessary.

### 11.3. Fuse replacement

Locate the fuse, which protects the lamp and electronics, in the base of the unit, as described in section 5.2 **Altering the operating voltage and frequency**. The fuse panel is shown in the picture which follows.

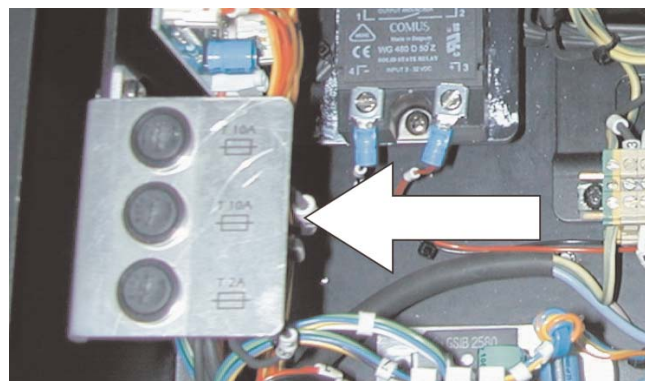

Using a multimeter, test the condition of the fuse, replacing it with one of equivalent type if necessary.

## 11.4. Electronic motor alignment

### ATTENTION!!

This procedure should only be undertaken by qualified and experienced technical personnel.

The display panel of the **Panorama Power MK2** allows for the electronic alignment of the projector's motors in the optical system. This procedure is performed by coemar at the factory. It may be useful to perform this procedure in the case of internal components being replaced.

Altering the factory settings may radically alter the functioning of the projector. Carefully read all of the following prior to attempting any changes.

### Electronic calibration

### ATTENTION!!

The alignment procedure can only be carried out when DMX 512 signal is connected.

1. Press the **menu** button and then **enter** to confirm.
2. Press the **+** or **-** button until **FUNC** is displayed. Then press **enter**.
3. Press the **+** or **-** button until **RESE** is displayed.
4. Press the **enter** and **menu** buttons simultaneously, holding them for at least **10"**. The motors will perform a reset and the display will show **----** for a few seconds. After this, the display will show **DIMM** confirming that you have entered electronic calibration mode.
5. Press the **+** or **-** button until the motor you wish to align is displayed and then press the **enter** button.
6. Press the **+** or **-** button until the correct calibration value is displayed and then press the **enter** button.  
Simultaneously pressing the **+** and **-** buttons to return the calibration value to 128 (default).
7. To exit calibration mode press **+** or **-** button until **END** is displayed and confirm this by pressing **enter**.

The following diagram displays the menu navigation system.

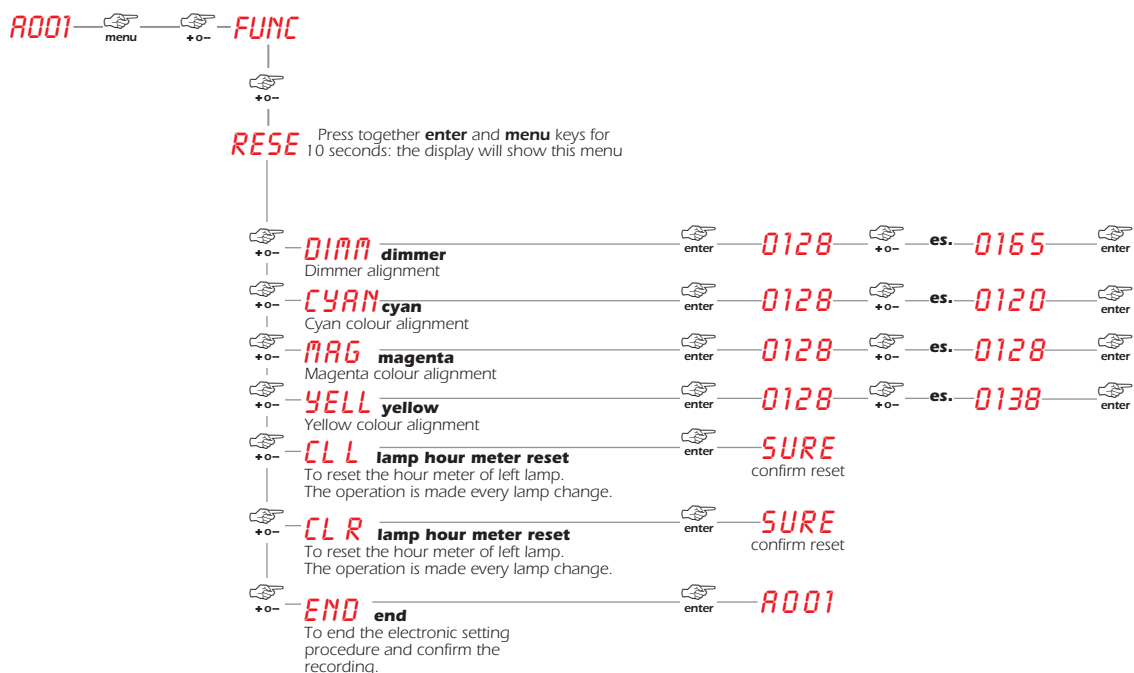

## 11.5. Resetting the counter

The lamp life counter needs to be reset to zero at every lamp change to provide accurate information on lamp life. To do this you will need to access the calibration menu (see section **11.4 Electronic motor alignment**). The following are the required steps:

1. Press the **menu** button and then press **enter**.
2. Press the **+** or **-** buttons until **FUNC** is displayed. Confirm this by pressing **enter**.
3. Press the **+** or **-** buttons until **RESE** is displayed.
4. Press the **menu** and **enter** buttons simultaneously, holding them pressed for about 10 seconds. The unit's motors will perform a reset and the display will show **----** for a few seconds. At the end of this, the display will show **DIMM** confirming you have entered calibration mode.
5. Press the **+** or **-** buttons until **CL R** is displayed (to access the lamp life counter for the right lamp) and press **enter**.
6. The display will show **SURE**. Confirm this by pressing **enter**.



## English

7. Press the + or - buttons until **CL L** is displayed (to access the lamp life counter for the left lamp) and press **enter**.
8. The display will show **SURE**. Confirm this by pressing enter.
9. To exit calibration mode, press the + or - button until **END** is displayed. Confirm this by pressing **enter**.

**N.B.** In the **HOUR** section of the **MEAS** menu, you may confirm that the **LIFE** values have been reset, whilst the other measures **LIFS** (total lamp life) and **UNIT** (projector life) remain unaltered.

## 12. Spare parts

All the components of the **Panorama Power MK2** are available as replacement spares from your authorised **Coemar** service centre. Accurate description of the fixture, model number, and type will assist us in providing for your requirements in an efficient and effective manner.

## 13. Patents

**Panorama Power MK2** is protected by various international patents which prohibit copying of the unit in total or in part.

## 14. Error messages

**SNER:**

### **SYNCHRONISATION Error**

Check and possibly replace the U9 opto-isolator.

**EPER:**

### **EEPROM Error**

The EEPROM is either defective or absent; refer to your coemar service centre for a replacement component.

**OTER:**

### **DATA Error**

The initial parameter settings are incorrect or corrupt; the projector has reloaded its factory default settings. Turn the projector off and on again. Should the error reoccur, refer the unit to your authorised coemar service centre to have the EEPROM check and possibly replaced.

**ADER:**

### **DMX ADDRESS Error**

The projector is not receiving all DMX channels needed to operate correctly. Check the DMX address indicated on the display and the channel numbers being outputted from the controller. Note that not all controllers will output all 512 channels.

**ER20÷ER99:** **SYSTEM Error**

Turn the unit off and on again. If the error persists, contact your authorised coemar service centre.

## 15. Frequently asked questions

The following table outlines various problems and their possible solutions.

Problem	Possible solution
<b>Panorama Power MK2</b> will not turn on	<b>Panorama Power MK2</b> does not have mains power: <ul style="list-style-type: none"><li>- Check that the mains power cable is connected to power.</li><li>- Check the input voltage.</li><li>- Check and replace the fuse if necessary.</li></ul>
<b>Panorama Power MK2</b> does not respond to DMX signal.	DMX may not be being received by the <b>Panorama Power MK2</b> : <ul style="list-style-type: none"><li>- Check controller output and all DMX cables.</li><li>- Check the display panel to ensure that no function which inhibits DMX control has been selected.</li><li>- <b>Panorama Power MK2</b> may have an incorrect DMX address: Check the unit's DMX address.</li></ul>
The <b>Panorama Power MK2</b> has been set to MASTER but is not running any programs	<ul style="list-style-type: none"><li>- Check that no other projector in the series has been designated as a MASTER.</li><li>- Check that there is no incoming <b>DMX</b> signal (a conflict will occur with MASTER signals and DMX signal).</li></ul>



**Coemar s.p.a.**

via Inghilterra 2/A - 46042 Castel Goffredo (Mantova) Italy  
ph. +39 0376/77521 - fax +39 0376/780657  
info@coemar.com

**Coemar** si riserva il diritto di apportare modifiche senza preavviso.  
**Coemar** reserves the right to effect modifications without notification