

miniCYC MB

...magneticballast

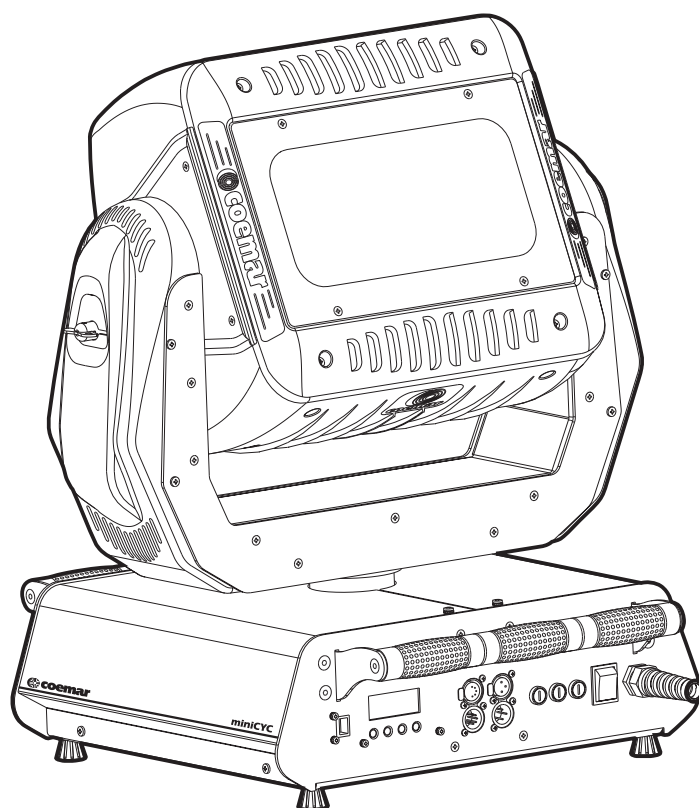

manuale di istruzioni
instructions manual

Version 1.1

 **coemar**
LIGHT EMOTION

miniCYC MB

numero di serie/serial number

data di acquisto/date of purchase

fornitore/retailer

indirizzo/address

cap/città/suburb

provincia/capital city

stato/state

tel./fax/

Prendete nota, nello spazio apposito, dei dati relativi al modello e al rivenditore del vostro **miniCYC MB**: in caso di richiesta di informazioni, pezzi di ricambio, servizi di riparazione o altro ci permetteranno di assistervi con la massima rapidità e precisione.

*Please note in the space provided above the relative service information of the model and the retailer from whom you purchased your **miniCYC MB**: This information will assist us in providing spare parts, repairs or in answering any technical enquiries with the utmost speed and accuracy.*

ATTENZIONE: la sicurezza dell'apparecchio è garantita solo con l'uso appropriato delle presenti istruzioni, pertanto è necessario conservarle.

WARNING: the security of the fixture is granted only if these instructions are strictly followed; therefore it is absolutely necessary to keep this manual.

Index

1. Packaging and transportation	Pag. 4
1.1. Packaging	" 4
1.2. Transportation	" 4
2. General information	Pag. 4
2.1. Important safety information	" 4
2.2. Warranty conditions	" 5
2.3. CE norms	" 5
3. Product specifications	Pag. 5
3.1. Technical characteristics	" 5
3.2. Dimensions	" 5
3.3. Projector components	" 5
4. Installation	Pag. 6
4.1. Mechanical installation	" 6
4.2. Safety connections	" 6
4.3. Pan and tilt movement lock	" 7
4.4. Adjusting beam angle	" 8
4.5. Barndoor installation	" 9
5. Powering up	Pag. 10
5.1. Operating voltage and frequency	" 10
5.2. Altering the operating voltage	" 10
5.3. Mains connection	" 11
6. DMX signal connection	Pag. 12
7. Turning on the projector	Pag. 13
7.1. DMX addressing	" 13
7.2. DMX functions	" 14
8. Display panel functions	Pag. 15
8.1. Quick guide to menu navigation	" 15
8.2. Measure and test (MEAS)	" 16
8.3. Function settings (FUNC)	" 17
8.4. Rapid scrolling	" 17
8.5. Connecting the DR1	" 18
8.6. Use of RJ45 connector	" 18
8.7. Turning on the projector with no articulated movement	" 18
9. Lamp installation and alignment	Pag. 19
9.1. Lamp installation	" 19
9.2. Aligning the lamp in the optical path	" 20
10. Opening up the projector	Pag. 21
11. Thermal protection	Pag. 22
12. Maintenance	Pag. 22
12.1. Periodic cleaning	" 22
12.2. Periodic maintenance	" 22
12.3. Fuse replacement	" 22
12.4. Electronic motor alignment	" 23
12.5. Resetting counters	" 24
12.6. Software upload	" 24
12.7. Software download	" 24
13. Spare parts	Pag. 25
14. Accessory	Pag. 25
15. Patent	Pag. 25
16. Error messages	Pag. 25
17. Frequently asked questions	Pag. 25

English

Congratulations on having purchased a **Coemar** product. You have assured yourself of a fixture of the highest quality, both in componentry and in the technology used. We renew our invitation to you to complete the service information on the previous page, to expedite any request for service information or spares (in case of problems encountered either during, or subsequent to, installation). This information will assist in providing prompt and accurate advice from your **Coemar** service centre.

Following the instructions and procedures outlined in this manual will ensure the maximum efficiency of this product for years to come.

1. Packaging and transportation

1.1. Packaging

Open the packaging and ensure that no part of the equipment has suffered damage in transit. In case of damage to the equipment, contact your carrier immediately by telephone or fax, following this with formal notification in writing.

Packing list

Ensure the packaging contains:

- 1 **miniCYC MB**
- 1 **instruction manual**
- 2 **cam-lock support brackets**
- 2 **additional diffusion filters (horizontal and vertical)**

1.2. Transportation

The **miniCYC MB** should be transported in its original packaging or in an appropriate flight case.

We recommend the use of the two inbuilt mechanical stops to block the articulated pan and tilt movement (for further information, see section 4.3. **Pan and tilt movement lock**).

2. General information

2.1. Important safety information

Fire prevention:

1. **miniCYC MB** utilises two Philips **MSD/2 250W** lamps; the use of any alternative lamp is not recommended and will null and void the fixture's warranty.
2. Never locate the fixture on any flammable surface.
3. Minimum distance from flammable materials: 0,5 m.
4. Minimum distance from the closest illuminable surface: 2 m.
5. Replace any blown or damaged fuses only with those of identical values. Refer to the schematic diagram if there is any doubt.
6. Connect the projector to mains power via a thermal magnetic circuit breaker.

Preventing electric shock:

1. High voltage is present in the internals of the unit. Isolate the projector from mains supply prior to performing any function which involves touching the internals of the unit, including lamp replacement.
2. For mains connection, adhere strictly to the guidelines outlined in this manual.
3. The level of technology inherent in the **miniCYC MB** requires the use of specialised personnel for all service applications; refer all work to your authorised **Coemar** service centre.
4. A good earth connection is essential for proper functioning of the projector. Never operate the unit without proper earth connection.
5. Mains cables should not come into contact with other cables.
6. Do not operate the projector with wet hands or in an area where water present.
7. The fixture should never be located in an exposed position, or in areas of extreme humidity. A steady supply of circulating air is essential.

Protection against ultraviolet radiation:

1. Never turn on the lamp if any of the lenses, filters, or the carbon fibre housing is damaged; their respective functions will only operate efficiently if they are in perfect working order.
2. Never look directly into the lamp when it is operating.

Safety:

1. The projector should always be installed with bolts, clamps, and other fixings which are suitably rated to support the weight of the unit.
2. Always use a secondary safety chain of a suitable rating to sustain the weight of the unit in case of the failure of the primary fixing point.
3. The external surface of the unit, at various points, may exceed 150°C. Never handle the unit until at least 10 minutes have elapsed since the lamp was turned off.
4. Always replace the lamp if any physical damage is evident.
5. Never install the fixture in an enclosed area lacking sufficient air flow; the ambient temperature should not exceed 35°C.
6. A hot lamp may explode. Wait at least 10 minutes after the unit has been turned off prior to attempting to replace the lamp.
7. The projector contains electronic and electrical components which should under no circumstances be exposed to contact with water, oil or any other liquid. Failure to do so will compromise the proper functioning of the projector.

Articulated movement

The projector has a pan range of 540° in its base and a tilt range 270° in its yoke; do not obstruct the projector whilst it is undertaking articulated movement.

Forced ventilation

You will note several air vents on the body of the projector. To avoid any problems associated with overheating, never obstruct any of these vents as this may seriously compromise the proper operation of the unit.

Protection rating against penetration by external agents:

1. The fixture is classified ordinary apparatus ; its protection grade against penetration by external agents, solid or liquid, is **IP 20**

2.2. Warranty conditions

1. The fixture is guaranteed for a period of 12 months from the date of purchase against manufacturing or materials defects
2. The warranty does not extend to damage caused by inappropriate usage or use by inexperienced operators.
3. The warranty is immediately void if the projector has been operated or dismantled by unauthorised personnel
4. The warranty does not extend to fixture replacement
5. The serial number of the projector is required for any advice or service from your authorised **Coemar** service centre

2.3. CE norms

The projector meets or exceeds all applicable CE requirements.

3. Product specifications

3.1. Technical characteristics

Power:	208/230/240 Vac 50/60Hz
Nominal current:	3.5A @ 230V
Maximum current:	6A
Power factor:	cos ϕ = 0,9
Lamp wattage:	2 x 250W MH
Maximum ambient temperature:	35°C / 95° F
Weight:	37 Kg / 81.4 Lbs
IP rating:	IP20

3.2. Dimensions

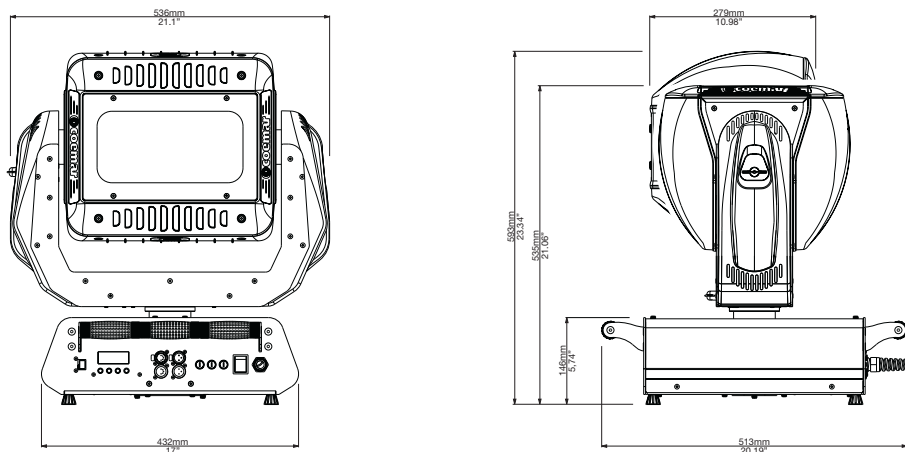

3.3. Components

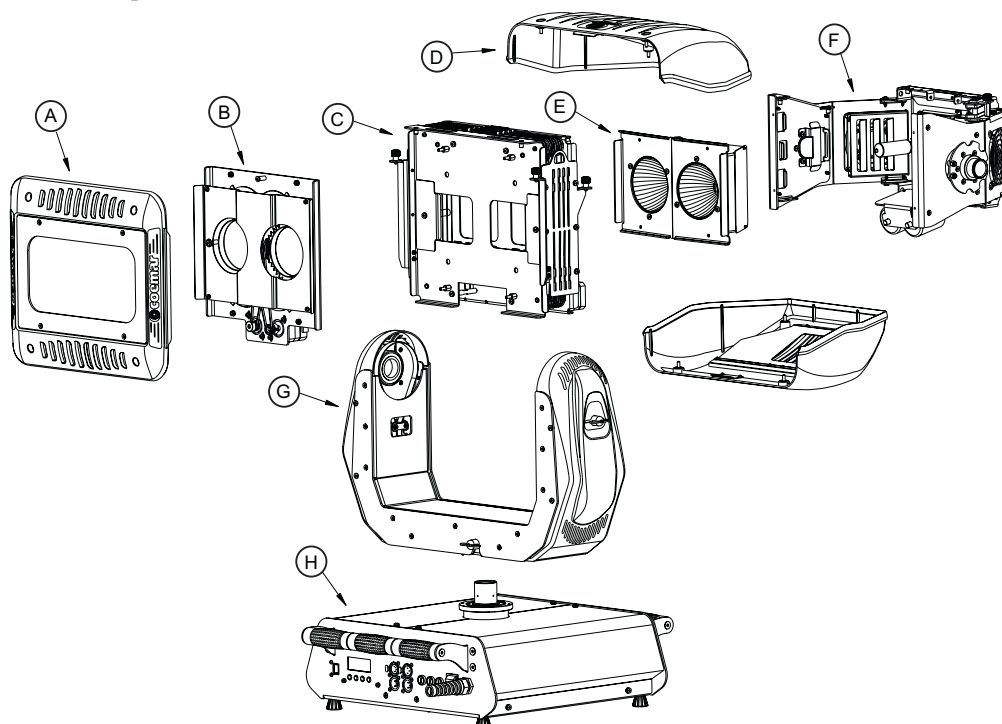

Component description

- A.** Front cover
- B.** Dimmer group
- C.** Colours changer group
- D.** Cover
- E.** Reflectors assembly
- F.** Lamps assembly
- G.** Yoke
- H.** Base

4. Installation

4.1. Mechanical installation

miniCYC MB may be either floor or ceiling mounted. For floor mounting, the unit is provided with four rubber mounting feet. For ceiling mounted installations, **Coemar** includes two cam-lock (**A**) support brackets.

The two cam-lock brackets may be mounted in two different positions (**B** & **C**) on the base of the **miniCYC MB**. The cam-lock brackets are affixed via a 1/4 nut. Please ensure that they are correctly seated and firmly tightened into position.

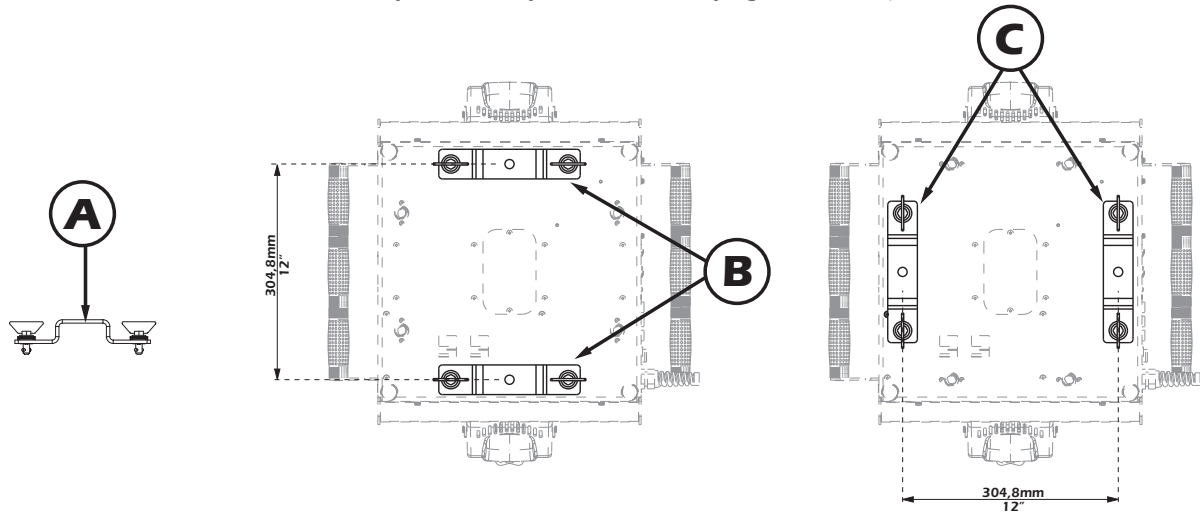

For ceiling mounted installations we suggest the use of appropriate clamps or fixings "**D**" to attach the fixture to the mounting surface. Clamps may be attached to the central hole provided in the cam-lock brackets, as shown in the following diagram.

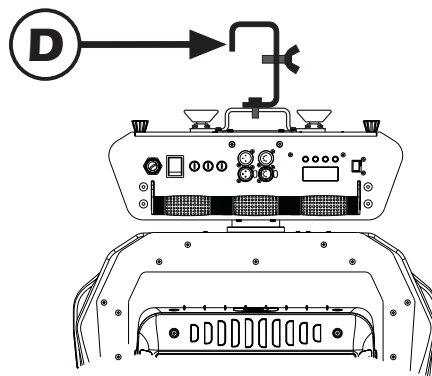

ATTENTION!!

Ensure that the structure from which the unit is hung is of sufficient rating to hold the weight of the unit, as are any clamps, nuts and bolts used to hang the unit.

The structure should also be sufficiently rigid so as not to move or shake whilst the projector moves during its operation. Do not install the projector in locations where it is readily accessible by authorised or untrained personnel.

4.2. Safety connections

If the **miniCYC MB** is affixed to a mobile structure the use of a safety chain designed to meet relevant safety standards is recommended. You may attach the safety chain to the holes "**E**" located on the base of the fixture and to the structure itself.

If using an after-market safety chain not manufactured by **Coemar**, ensure that it is of sufficient rating to hold the weight of the unit.

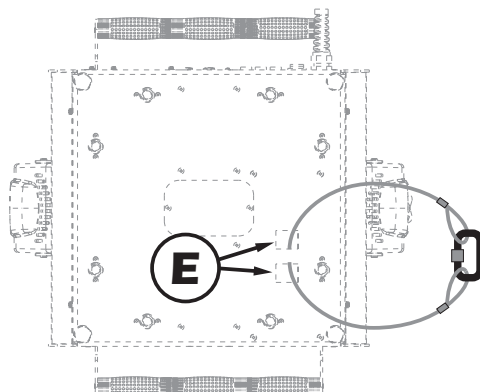

4.3. Pan and tilt movement lock

Two mechanical locking devices allow to stop the pan and tilt movement of the unit, when it's off.

ATTENTION!!

Before supplying the unit ensure that the devices are not in 'LOCK' position, to make the unit free to reset.

Locking device "F" stop the pan rotation (base).

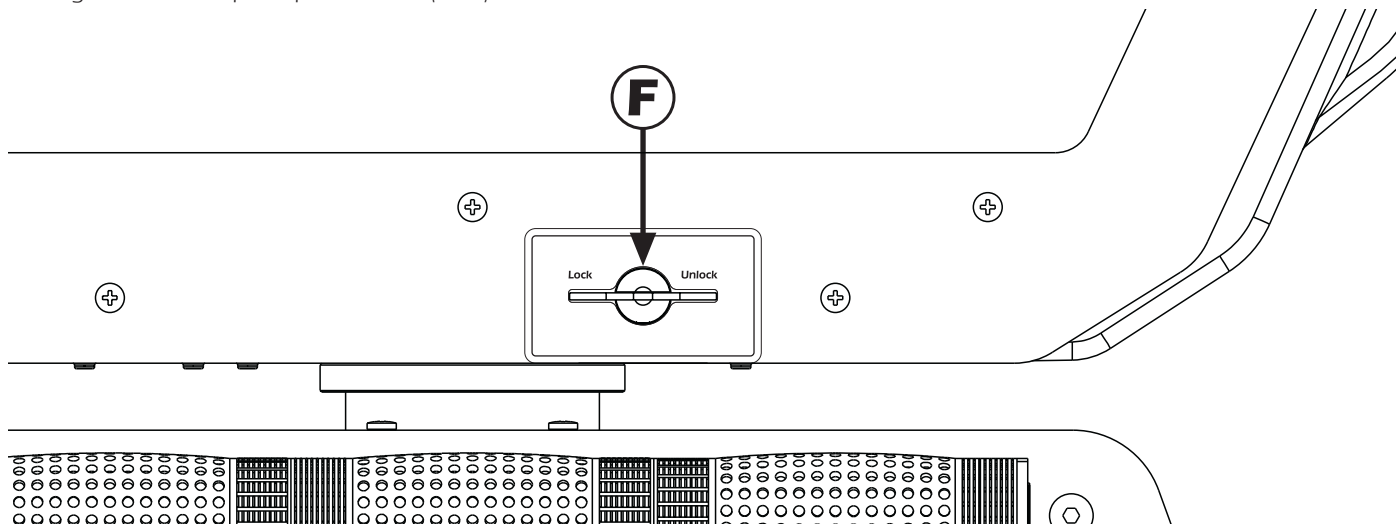

To stop the rotation, position the device to "LOCK" (refer to the arrow on the handle). The yoke can be locked only in some positions (at 90° angles in respect to the base). If the device doesn't turn to "LOCK" position do not force it but slightly move the yoke. Position the device to "UNLOCK" to make the unit free to rotate.

Locking device "G", located on the side of the yoke, stop the tilt movement (yoke).

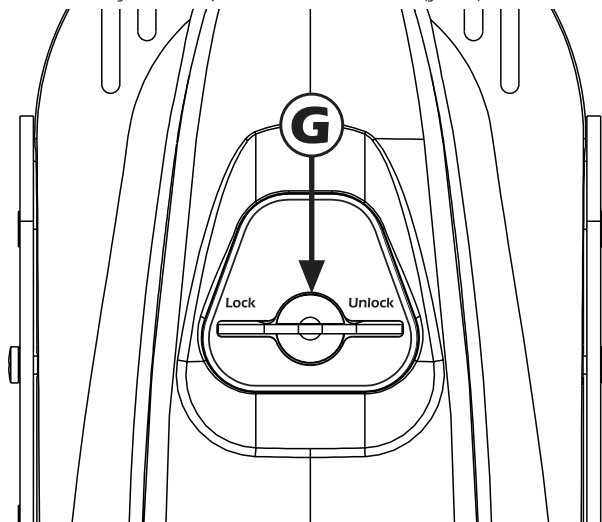

To stop the rotation, position the device to "LOCK" (refer to the arrow on the handle). The yoke can be locked only in some positions (at -90° , -45° , 0° , $+45^\circ$ e $+90^\circ$ angles in respect to the yoke).

If the device doesn't turn to "LOCK" position do not force it but slightly move the body of the unit. Position the device to "UNLOCK" to make the unit free to rotate.

English

4.4. Adjusting beam angles

The **miniCYC MB** has 4 different diffusion filters available which can be used to alter the dimensions and shape of the beam output, thus making it suitable for a variety of situations.

Prior to undertaking the following procedure, ensure that either the projector is switched off or its dimmer is fully on.

ATTENTION!!

Direct exposure to the output beam of the projector is not recommended.

The following pictures indicate the correct procedure for replacing the various diffusion filters.

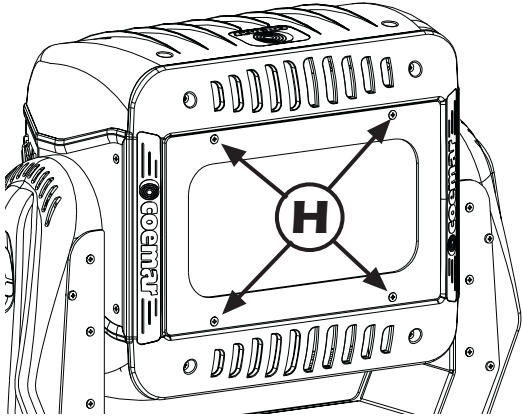

1. Using a suitable tool to remove the four screws "H" which affix the frontal plate.

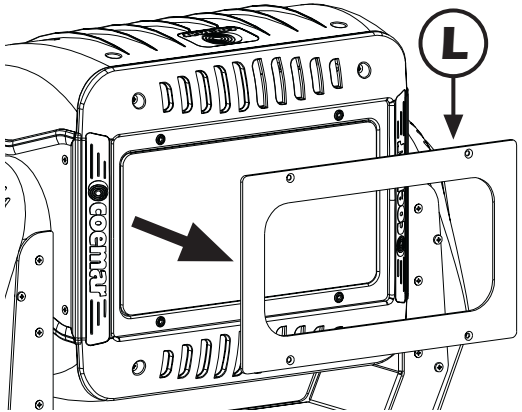

2. Remove the front plate "L".

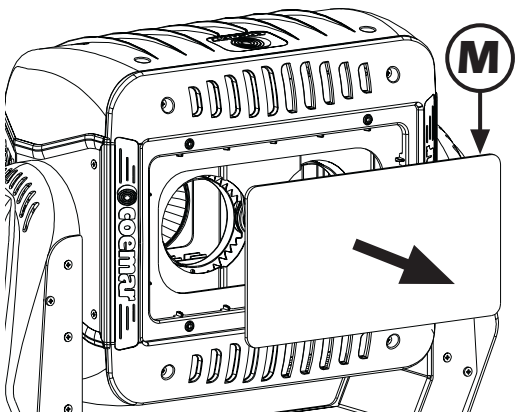

3. Remove the filter "M" currently in position
4. Insert the appropriate filter to suit the beam dimensions you wish to achieve. Select from filter which alter different diffusion patterns and those which alter the vertical or horizontal output angles.
5. When you have inserted the appropriate filter, replace the front plate and the four screws previously removed.

The table below illustrates the various beam angles which can be achieved by the **miniCYC MB** using the diffusion filters.

Filter type	Minimum zoom		Maximum zoom	
	Horizontal beam angle	Vertical beam angle	Horizontal beam angle	Vertical beam angle
1. Standard diffusion filter (cod. VT248)	16°	12°	56°	43°
2. Maximum diffusion kit (accessory cod. 9832)	49°	49°	74°	72°
3. Horizontal diffusion filter (cod.VT250)	54°	9°	77°	48°
4. Vertical diffusion filter (cod. VT249)	13°	48°	52°	74°

Additional adjustment of the projected beam angle may be achieved using the 4 barndoors as as described in the following paragraphs.

4.5. Barndoors installation

The 4 leaf barndoors (accessory cod. **9829**) can be used to adjust and shape the projected beam angle of the **miniCYC MB** to further suit your needs.

Prior to undertaking the following procedure, ensure that either the projector is switched off or its dimmer is fully on.

ATTENTION!!

Direct exposure to the output beam of the projector is not recommended.

The following pictures indicate the procedure needed to install the barndoors.

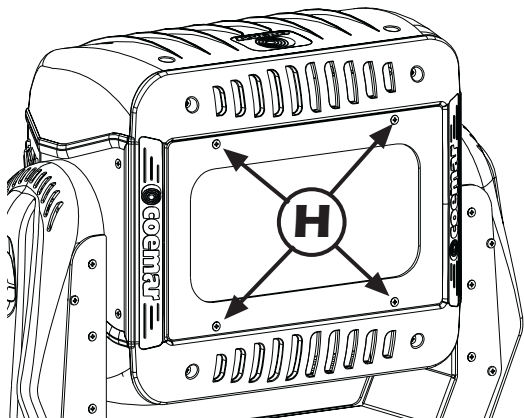

1. Using a suitable tool to remove the four screws "H" which affix the frontal plate.

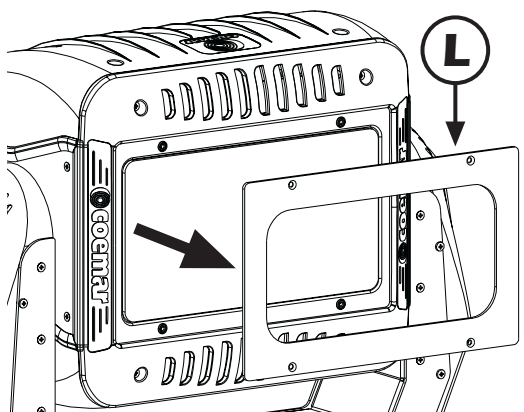

2. Remove the frontal plate "L".

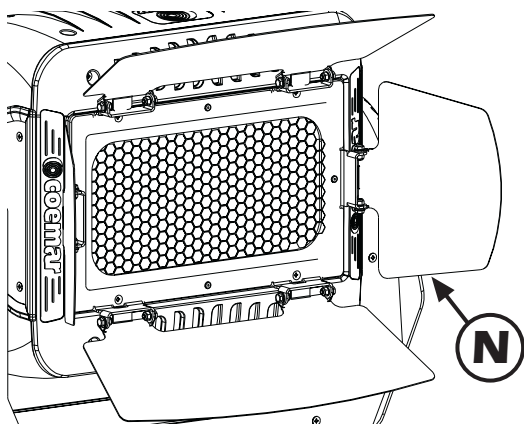

3. Install the barndoors "N" and replace the four screws "H" previously removed.
4. Position the barndoors to achieve the required effect.

5. Powering up

5.1. Operating voltage and frequency

The projector may operate at voltages of **208V**, **230V** or **240V AC** at a frequency of 50 or 60Hz. **Coemar** presets (barring specific requests) a voltage of 230V at a frequency of 50Hz. The preset voltage and frequency is indicated on the base of the projector.

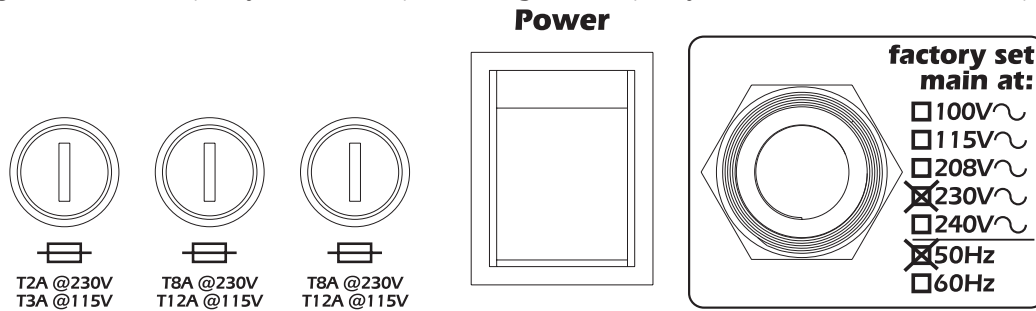

5.2. Altering the operating voltage and frequency (Reserved for technical personnel only)

If the factory preset operating voltage and frequency do not correspond to those in use in your country of operation, you may alter the settings as described in the following paragraphs.

ATTENTION!!

Incorrect selection of operating voltage and frequency will seriously compromise the functioning of the projector and will immediately void the warranty.

Loosen the screws "A" on the cover of the base of the unit, as shown in the diagram below, using an appropriate screwdriver, thereby removing the two covers completely and allowing access to the internal components of the base of the **miniCYC MB**.

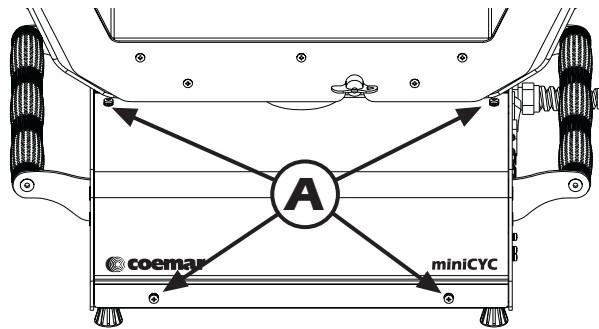

Locate the transformer in the base of the unit.

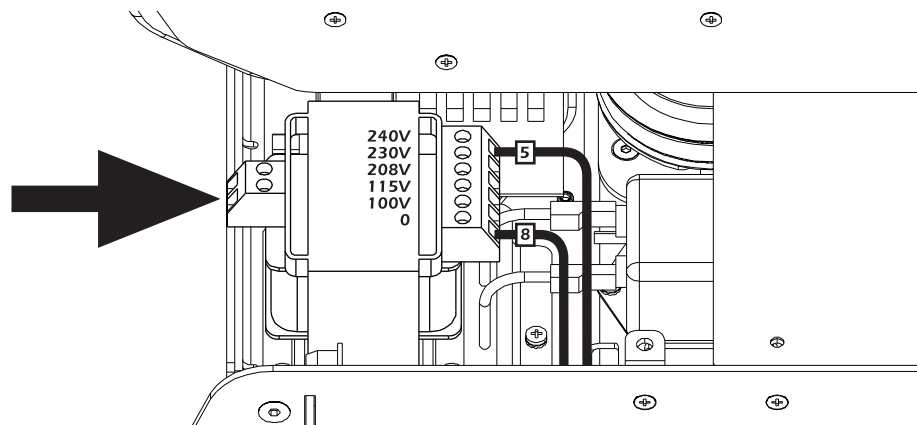

Select a voltage from amongst 208V, 230V or 240V by disconnecting cable n° 5 and moving it to the correct voltage. Refer to the sticker located on the transformer to ensure the proper terminal is selected for your requirements.

Cable number 8 must not have its position altered under any circumstances!

Locate the ballast inside the base.

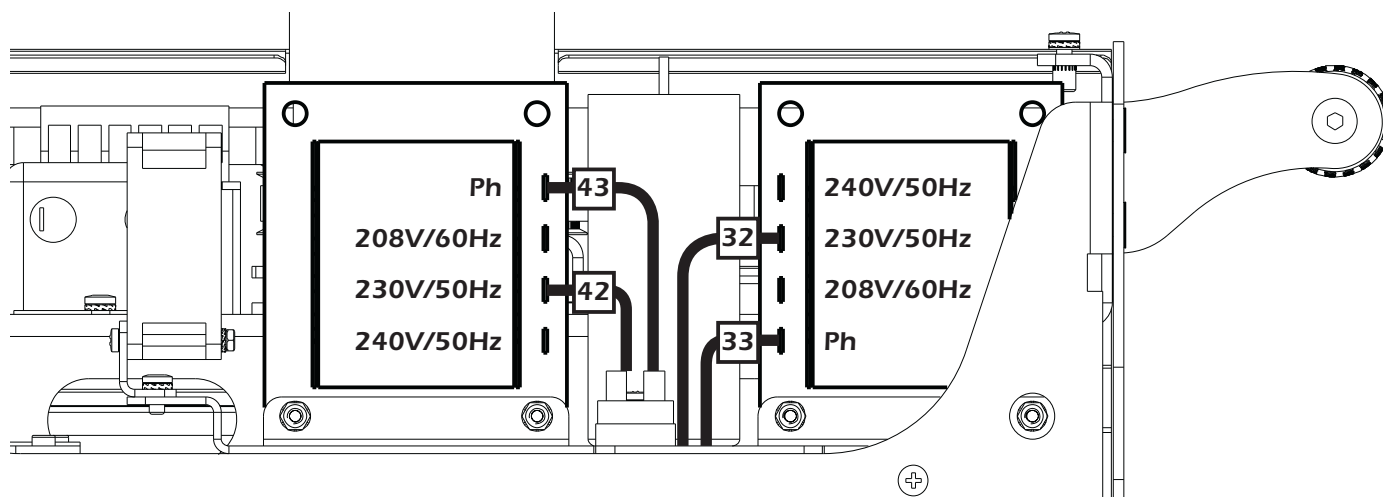

Cables **32** and **42** determine the operating voltage and frequency. Move them to the required value: 208V/60Hz, 230V/50Hz or 240V/50Hz on the ballast. Refer to the stickers on the ballast to ensure correct selection is made.

Cables number 33 and 43 must not have its position altered under any circumstances!

When you have made changes, note these on the outside of the **miniCYC MB**.

Replace and fasten all the housings as per their original positions.

5.3. Mains connection

Mains cable characteristics

The mains cable provided is thermally resistant, complying to the most recent international standards. It meets or exceeds VDE and IEC norms, IEC 331, IEC 332 3C, CEI 20 35.

NB: In case of cable replacement, similar cable with comparable thermal resistant qualities must be used exclusively (cable 3x1.5 \varnothing external 10 mm, rated 300/500V, tested to 2KV, operating temperature $-40^{\circ} +180^{\circ}$, **Coemar** cod. CV5309).

Connecting to mains power

For connection purposes, ensure your plug is of a suitable rating to sustain the maximum current:

- 208/230/240V 3.5 amps constant current in normal operation

Locate the mains cable which exits the base of the unit and connect as shown below:

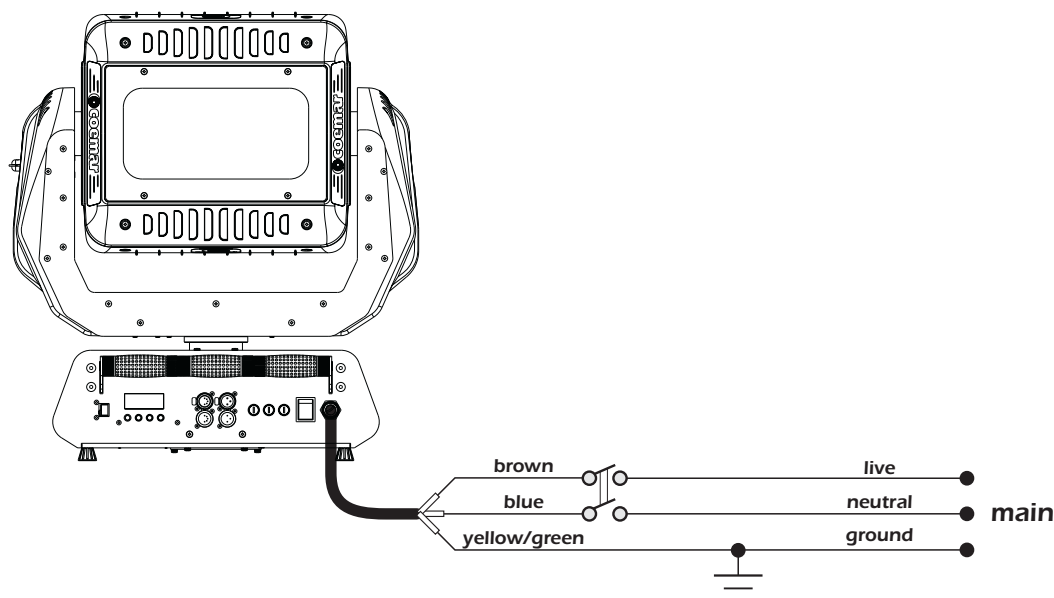

ATTENTION!!

- The use of a thermal magnetic circuit breaker is recommended for each projector. Strict adherence to all regulatory norms is highly recommended.
- **miniCYC MB** should never be supplied mains power via a Dimmer; this is potentially dangerous.
- Prior to powering up the projector, ensure that the model in your possession correctly matches the mains supply available to you.
- A good earth connection is essential for the correct operation of the **miniCYC MB**. Never connect the projector to main power if the green/yellow earth cable is not correctly connected
- All cable and plug connections should be carried out by fully qualified and licenced personnel only.

6. DMX signal connection

Control signal is digital and is transmitted via two pair screened $\varnothing 0.5\text{mm}$ cable as per international standards for the transmission of DMX512 data. Connection is serial, utilising XLR3 and XLR5 male and female sockets located on the base of the **miniCYC MB**, labeled **DMX 512 IN** and **OUT** (see diagram).

Plug/socket connections for XLR3 and XLR5 connectors

Pin connections conform to the international standard as per the following table:

- pin 1 = GND
- pin 2 = data -
- pin 3 = data +

If using a controller which output signal via an XLR 5 (5 pin) socket, do not use pins 4 and 5, leave them unconnected.

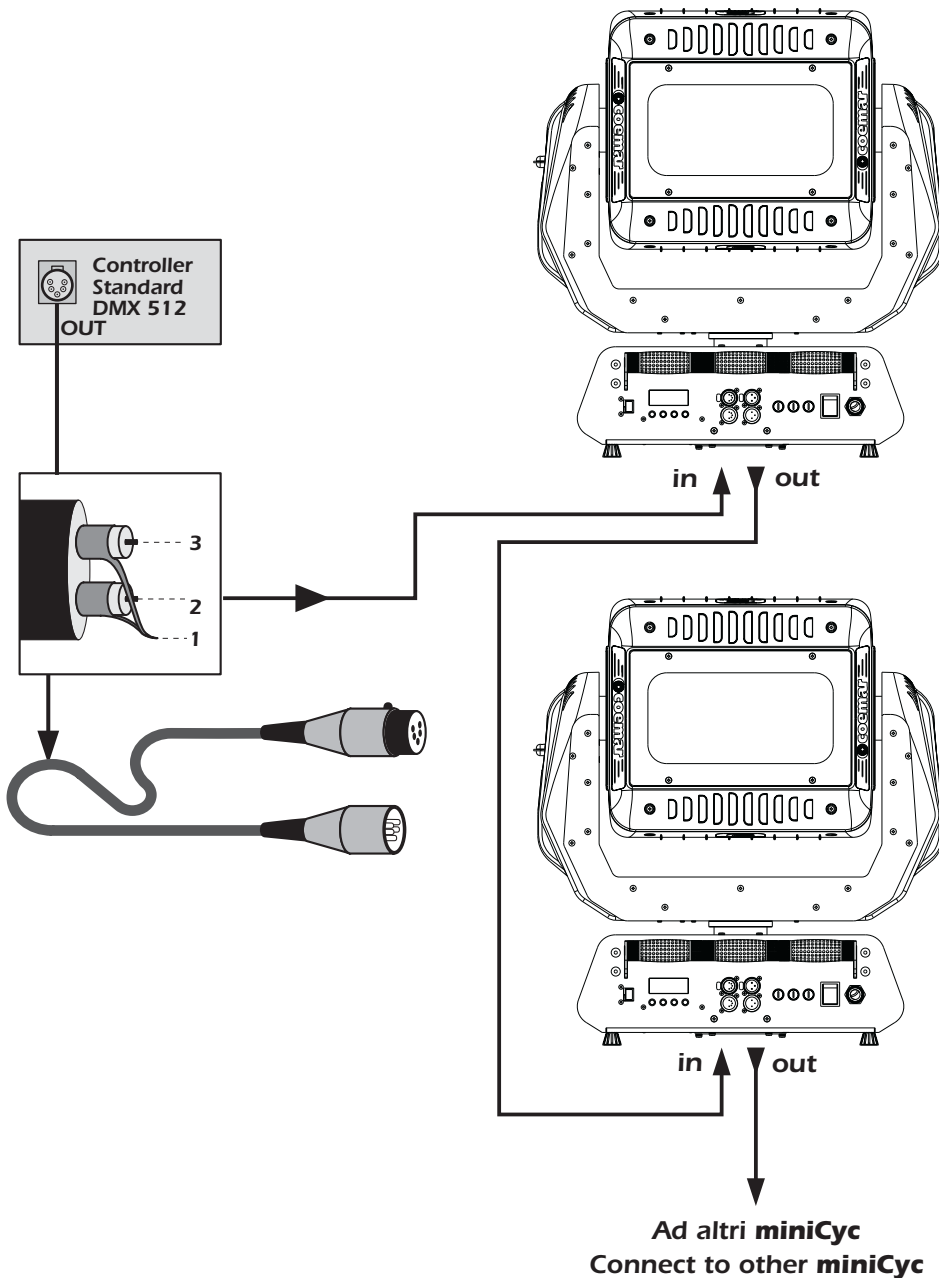

ATTENTION!!

Ensure that all data conductors are isolated from one another and the metal housing of the connector. Pin number 1 should never be connected to the device's power supply.

7. Turning on the projector

After having followed the preceding steps, turn on the projector via the main **Power** switch.

The display will show in sequence the software version installed in the 2 onboard microprocessors - the display micro "D" and the master micro "M".

For example, upon turning on power, the **miniCYC MB** may show:

01.02 (display pcb "D" software version)

M1.03 (master pcb "M" software version)

The projector will perform a reset function on all the internal and external motors. This will last some few seconds, after which it will be subject to the external signal from the controller. The display will remain fixed on indicating correct **DMX 512** signal reception.

If the display flashed, there is no DMX signal being received. Check your cabling and your controller.

7.1. DMX addressing

Each projector utilises **14** channels of **DMX 512** for complete control.

For further information, see section **7.2. DMX functions**.

DMX addresses

To ensure that each projector accesses the correct signal, it is necessary to correctly address each fixture. This procedure must be carried out on every projector being used. When powered up initially, each projector will show **A001** which indicates **DMX address 001**; a projector thus addressed will respond to commands on channel **1** to **14** from your **DMX controller**. A second unit should be addressed as **A015**, a third as **A029** and so on until the final projector has been addressed.

Altering DMX addresses

1. Press the **+** or **-** buttons until the display shows the required **DMX** address. The characters in the display will flash to indicate that the selection is not yet stored in memory.
2. Press the **enter** button to confirm your selection. The display panel will cease to flash and the projector will now respond to the new **DMX 512** address.



Important Note: holding down the **+** or **-** buttons will cause the display to alter at an increased speed, allowing a faster selection to be made.

ATTENTION!!

If you alter the DMX with no DMX controller connected, the characters in the display panel will continue to flash even after you have pressed the ENTER button.

English

7.2. DMX functions

channel	function	type of control	effect	decimal	percentage
1	X axis, base movement (pan) coarse	proportional	proportional coarse control of the base motor movement	0 - 255	0% - 100%
2	X axis, base movement (pan) fine	proportional	proportional fine control of the base motor movement	0 - 255	0% - 100%
3	Y axis, yoke movement (tilt) coarse	proportional	proportional coarse control of the yoke motor movement	0 - 255	0% - 100%
4	Y axis, yoke movement (tilt) fine	proportional	proportional fine control of the yoke motor movement	0 - 255	0% - 100%
5	movement speed	step	standard (fast)	0 - 10	0% - 4%
		step	ultra fast movement (best for programming positions)	11 - 25	4% - 10%
		proportional	vector mode (from fast to slow)	26 - 127	10% - 50%
		proportional	tracking mode (from fast to slow)	128 - 247	50% - 97%
		step	tracking mode (slow)	248 - 255	97% - 100%
6	dimmer	proportional	gradual adjustment of luminous intensity from 0 to 100%	0 - 255	0% - 100%
7	shutter, strobe	step	shutter closed	0 - 9	0% - 4%
		proportional	strobe effect with variable speed from slow to fast	10 - 66	4% - 26%
		step	shutter open	67 - 68	26% - 27%
		proportional	sequenced pulse effect, slow closing, fast opening (with variable speed from slow to fast)	69 - 125	27% - 49%
		step	shutter open	126 - 127	49% - 50%
		proportional	sequenced pulse effect, fast closing, slow opening (with variable speed from fast to slow)	128 - 184	50% - 72%
		step	shutter open	185 - 187	73% - 73%
		proportional	random strobe effect, non-synchronised, variable speed from slow to fast	188 - 244	74% - 96%
step	shutter open	245 - 255	96% - 100%		
8	zoom	proportional	proportional control of zoom from wide beam to narrow	0 - 255	0% - 100%
9	cyan	proportional	proportional control of the percentage of cyan colour in the light beam from 0 to 100%	0 - 255	0% - 100%
10	magenta	proportional	proportional control of the percentage of magenta colour in the light beam from 0 to 100%	0 - 255	0% - 100%
11	yellow	proportional	proportional control of the percentage of yellow colour in the light beam from 0 to 100%	0 - 255	0% - 100%
12	activate black-out synchronised with PAN/TILT movement	step	no effect	0 - 249	0% - 98%
			black-out of the beam light during PAN/TILT movement	250 - 255	98% - 100%
13	right lamp on/off	step	park, no function	0 - 10	0% - 4%
			right lamp off	11 - 29	4% - 11%
			park, no function	30 - 240	12% - 94%
			right lamp on	241 - 255	95% - 100%
14	both lamps on/off or left lamp on/off and motors reset	step	park, no function	0 - 10	0% - 4%
			left lamp off or both lamps off	11 - 29	4% - 11%
			pan and tilt reset (once only)	30 - 65	12% - 25%
			reset of cmv and zoom motors (once only)	66 - 100	26% - 39%
			reset all motors except dimmer (once only)	101 - 135	40% - 53%
			reset all motors (once only)	136 - 170	53% - 67%
			both lamps on (override ch 13)	171 - 249	67% - 98%
left lamp on	250 - 255	98% - 100%			

Note 1: the display panel may be used to disable the switching off of the lamp via DMX

Note 2: turning off the lamps and all reset functions are delayed by 6 seconds to prevent accidental activation

Note 3: the lamp on/off function can only be effected if an opposite level is set

Note 4: turning on/off both lamps using channel 14 has the override on channel 13 if its values are inside the park zone

To ignite the 2 lamps both channels number 13 and 14 must be set to a level between 241 and 255 and between 171 and 255 respectively. Lamps may also be ignited individually, using the display panel, as described in section **8.4 Function setting (FUNC)**.

8. Display panel functions

The display panel of the **miniCYC MB** shows all the functions available; it is possible to change some of those parameters and to add some functions.

Changing the preset settings made by **Coemar** can vary the functions of the device so that it may not respond to a **DMX 512** controller being used to control it. Carefully follow the instructions before applying any variations or selections.

NOTE: the symbol  shows which key has to be pushed to obtain the desired function .

8.1. Quick guide to menu navigation

For your convenience, the following is a guide to navigating the menu system of the projector.

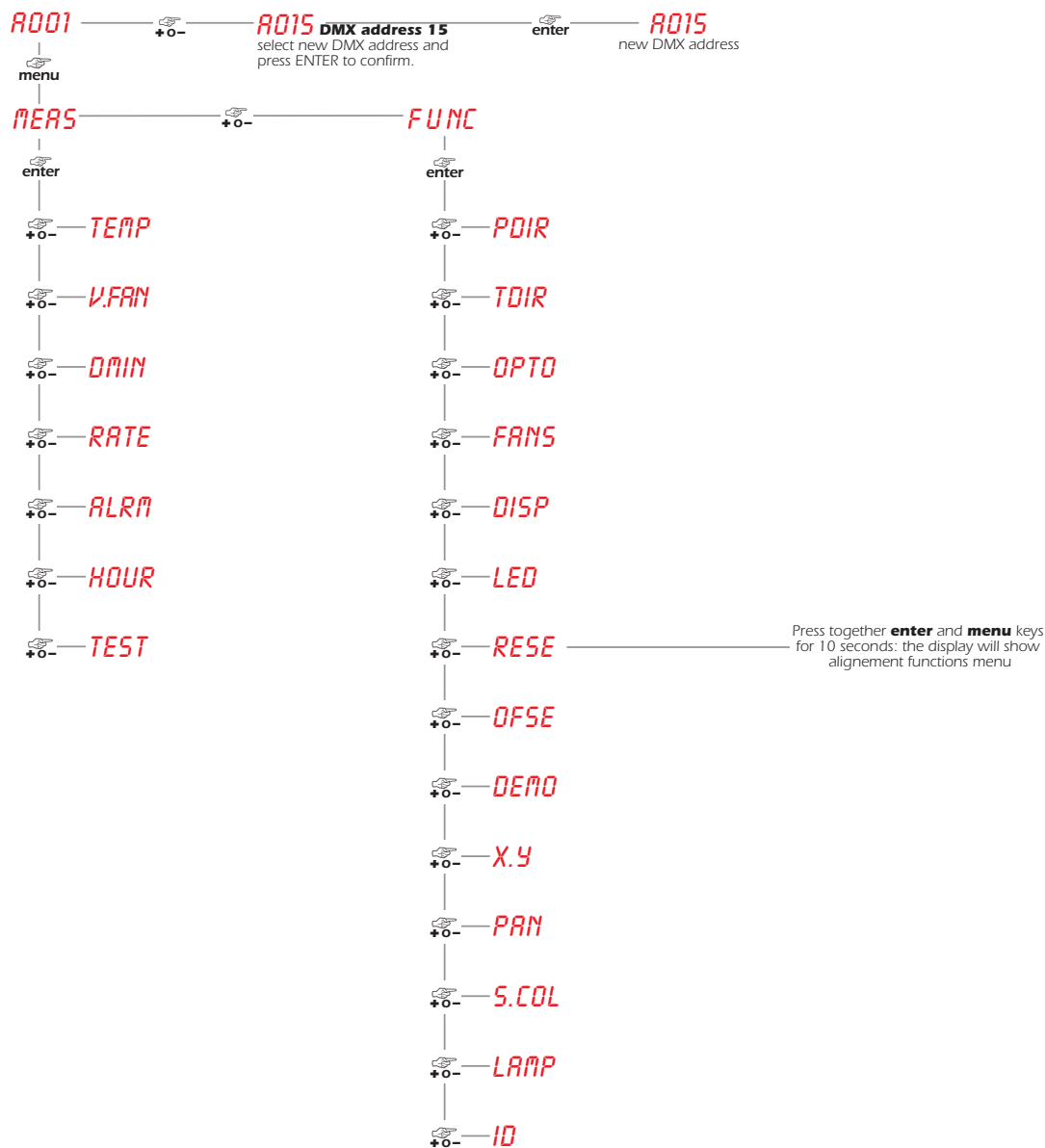

English

8.2. Measure and test (MEAS)

The internal microprocessor of the **miniCYC MB** allows for several diagnostic and output parameters to be displayed. You may record, in this menu, determine the position in which the projector will come to rest when turned on with no dmx signal attached.

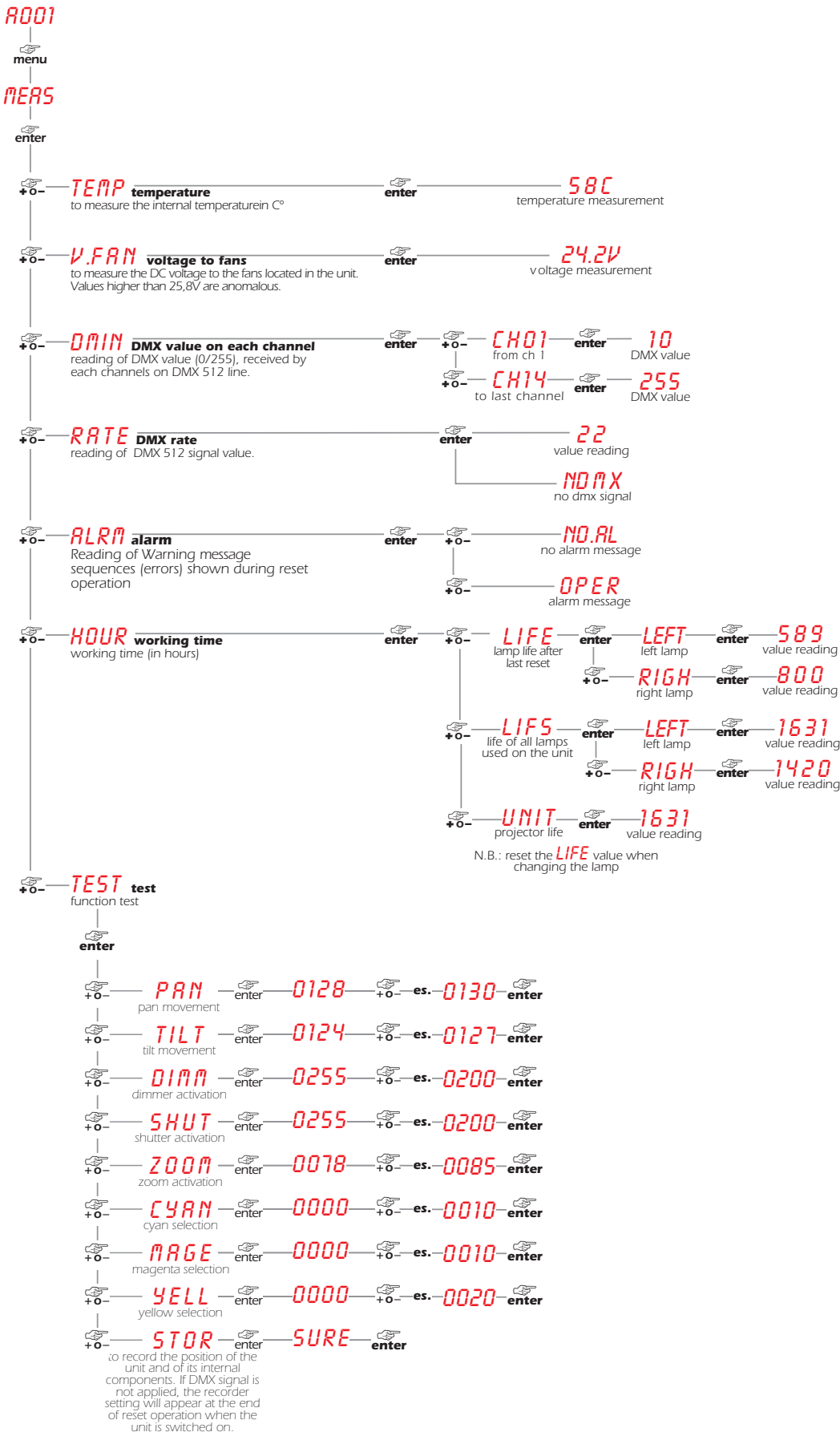

8.3. Function settings (FUNC)

The projector allows the altering of several functions and for selecting personalised settings.

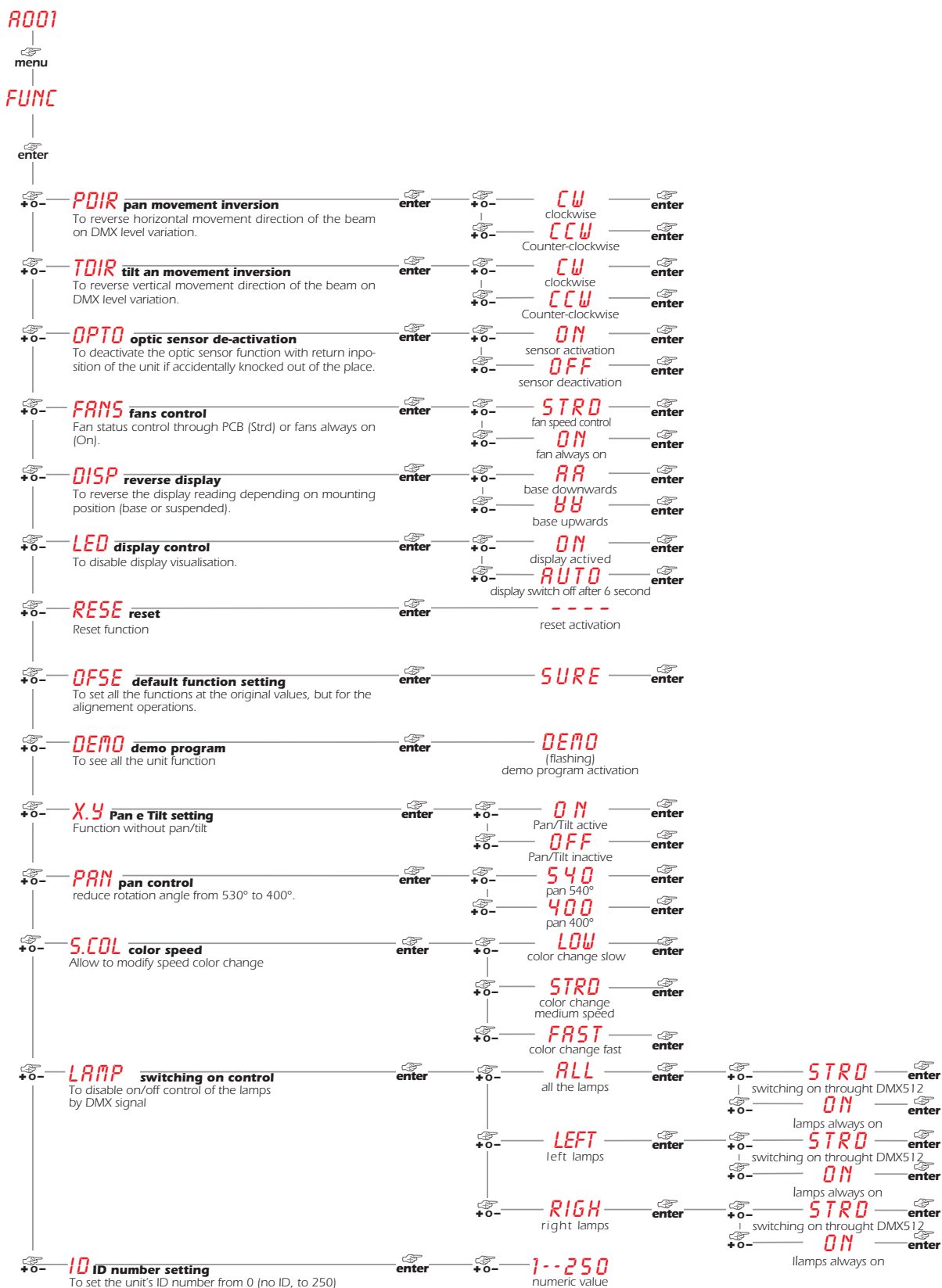

8.4. Rapid scrolling

Via the **miniCYC MB** display it is possible to rapidly scroll through the various numbers displayed in the menu in the following manner:

1. Pressing the **+** or **-** buttons will cause the number to scroll more quickly.
2. Pressing and holding the **+** button and then the **-** button will cause the numbers to jump to the highest value.
3. Pressing and holding the **-** button and then the **+** button will cause the numbers to jump to the lowest value.

English

8.5. Connecting the DR1

All the functions available via the display menu are also available via the **DR1** (cod. **9703**).

The **DR1** duplicates the display of the projector and eliminates the need for climbing up truss structures to gain direct physical access to the projector to alter such parameters as **DMX** address, reading outputs such as lamp life, setting master/slave configurations as well as all other functions available via the digital display unit on the projector.

The **DR1** is a remote device designed for technical users who need to perform tasks on the projectors whilst they may be located in inaccessible positions. It acts as a remote control.

In order to utilise the **DR1** remote device, you must first activate the identifying number of the projector **ID**, which must be unique in the particular DMX universe in which it is currently installed.

ATTENTION!!

- If you set a projector's identification number to "0" it will not be able to communicate with the DR1.
- Never assign the same ID to two or more projectors. This may jeopardise the functioning of the entire system. (The DR1 will show an error message).

The method for setting an identification number **ID** is shown below.

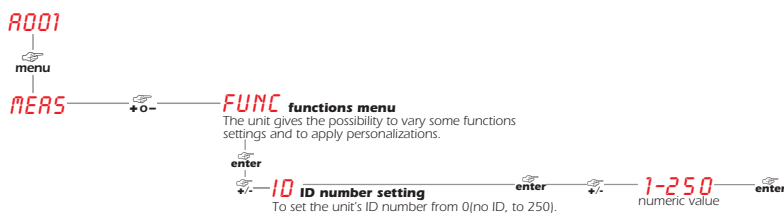

For further information, consult the **DR1** instruction manual.

8.6. Use of RJ45 connector

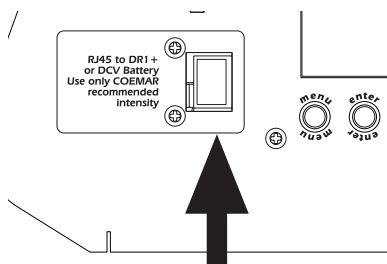

On panel of **miniCYC MB** base you find a RJ45 connector, as shown in picture, that can be used either for display supply and for software upgrade function.

It's possible to supply the display through an external battery, and access to menu functions, without connecting the unit to the mains.

RJ45 connector can also be used for the connection of **DR1+**, the remote control that allows to supply the display, to upgrade the software and to access to all the functions that are usually selectable from the **DR1**.

For more information pls. Read the manual of the different devices.

8.7. Turning on the projector with no articulated movement

This function may be useful should you need to power up the **miniCYC MB** whilst it is in its flight case or to re-address it or alter any parameters and you wish to in the absence of any articulated movement.

1. Turn on the projector whilst holding down the **enter**, **menu** and **-** buttons

The projector will proceed with a reset of all its motors with the exception of those which control articulated movement, the pan and tilt motors, which remain static.



2. You may alter the DMX address or any other parameter without any articulated movement occurring

3. To return to normal functioning of the **miniCYC MB** simply turn the projector off and on via the **Power** switch or activate the **Reset** function.

9. Lamp installation and alignment

The **miniCYC MB** utilises the Philips MSD/2 250W with GY 9,5 base lamps. These lamps are available via your **Coemar** distributor or service centre.

Lamp	Philips MSD/2 250W
Coemar code	105214/1
Power	250W
Luminous flux	18.000 lm
Colour temperature	8500° K
Base	GY 9,5
Approximate lamp life	2000 huors

ATTENTION!!

**Disconnct the unit from mains power prior to attempting lamp installation or replacement
Make sure the projector is sufficiently cooled.**

The fixture's internal temperature can reach 250° C after 5 minutes, with a maximum peak of 350° C; ensure that the lamp is cold prior to attempting removal. The fixture should be allowed to stand and cool for 10 minutes prior to its removal.

The lamps are part of the mercury vapour family of discharge lamps and must be handled with great care. The lamp operates at high pressure, and the slight risk of explosion of the lamp exists if operated over its recommended life. We recommend, therefore, that the lamp be replaced within the manufacturer's specified lamp life.

9.1. Lamp installation

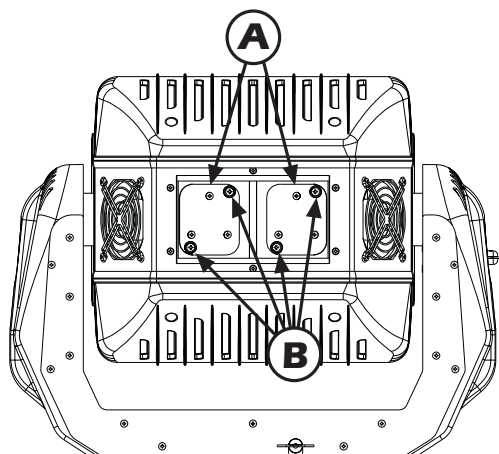

1. Identify the two lampholder assembly, left and right "A". Use a suitable tool to loosen the screws "B" which affix the lampholder assembly at the rear of the projector

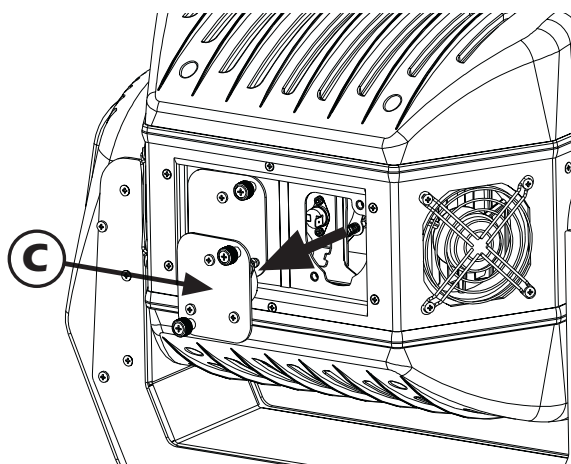

2. Remove the lampholder assembly "C".

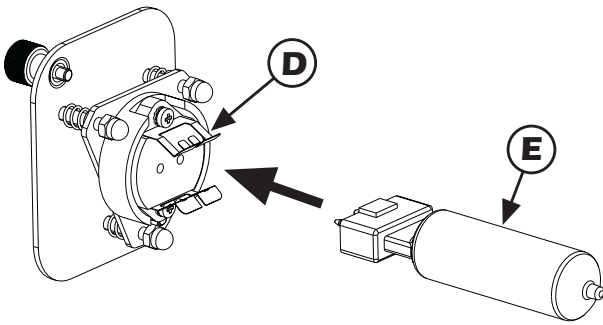

3. Identify the lampholder "D".

4. Insert the lamp "E" in the lampholder. The lamp used is manufactured from quartz glass and should be handled with care; always adhere to the instructions supplied in the lamp's packaging. Never touch the glass directly, use the tissue provided in the lamp's packaging. The GY 9,5 lampbase is asymmetrical in construction. **DO NOT USE UNDUE FORCE.** In case of difficulty, re-read the instructions and repeat the procedure.

5. Replace the lampholder assembly in its original position and refasten the two screws "C" which were previously removed.

ATTENTION!!

Each time you change the lamp, we recommend the following be carried out:

- realign the lamp in the optical path to flatten the beam to maximum uniformity and to avoid overheating dichroics .
- reset the lamp life counter (as described in section 12.5. Resetting the counter).

9.2. Aligning the lamp in the optical path

Aligning the lamp in the optical system is achieved via the 3 adjusters at the rear of the projector. This procedure should be undertaken to maximise output, properly align the lamp in the optical system and to avoid the possible overheating of the internal components due to the incorrect focusing of the beam onto components not intended to be exposed to this.

Alignment procedure

Alignment is effected by the 3 adjusters **A**, **B** and **C** located on the lampholder assembly. The lamp should be on, black-out and dimmer fully open, and no colours selected. The procedure should be undertaken on one lamp at a time to avoid interference amongst them. A beam from a lamp which is not aligned will result in a noticeable hotspot, the result of the position of the lamp with respect to the reflector. Using the 3 adjusters in unison, you will need to bring the hot-spot to the centre of the beam and then flatten the beam to maximum uniformity.

The three adjusters move the lamp horizontally, vertically and axially within respect to the reflector.

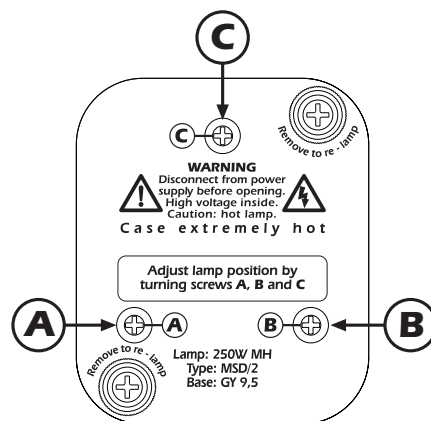

10. Opening up the projector

By removing the housing in the manner shown below, complete access to the projector's internals is possible.

ATTENTION!!

Always remove mains power and ensure the unit is sufficiently cooled prior to opening up the housing.

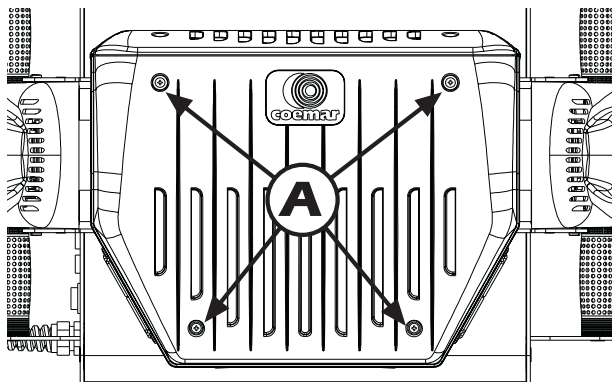

1. Using an appropriate screwdriver, remove the screws "A" which affix the housings and remove it.

To identify which part of the projector must be removed please position the unit so that the labels of the lampholder group are in the upright position. Now lock the unit by the locking device and remove the upper cover.

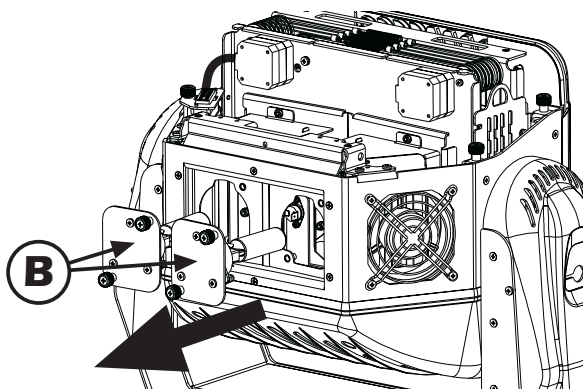

2. Take out the two lampholder assembly "B".

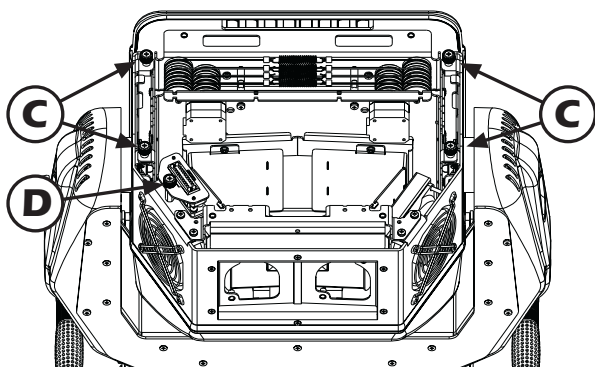

3. Using an appropriate screwdriver, remove the screws "C" which affix the colors changer and the connector "D".

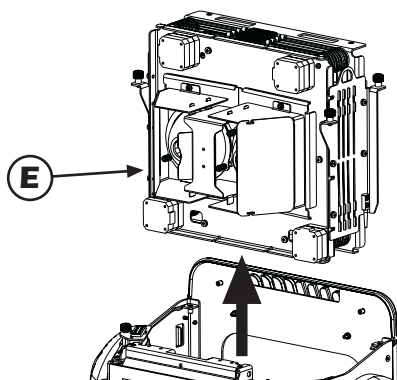

4. Remove the color changer assembly "E".

Now the assembly can be easily inspected.

5. Replace and fasten the assembly and the housings as per their original positions.

11 Thermal protection

A thermal sensor in the body of the **miniCYC MB** protects the unit against overheating.

The thermal sensor operates by removing voltage to the lamps if the ambient temperature rises above a preset maximum due to either less than ideal air circulation around the fixture or in the event of cooling fan failure.

12. Maintenance

Whilst every possible precaution has been taken to ensure the trouble-free operation of your **miniCYC MB**, the following periodic maintenance is highly recommended.

ATTENTION!!

Always remove mains power and ensure the unit is sufficiently cooled prior to opening up the housing.

To gain access to the internals of the unit refer to section **10. Opening up the projector housing** of this manual.

12.1. Periodic cleaning

Lenses and reflectors

Even a fine layer of dust can reduce the luminous output substantially. Regularly clean all lenses and the reflector using a soft cotton cloth, dampened with a specialist lens cleaning solution.

Fans and air passages

The fans and air passages must be cleaned approximately every 6 weeks; the period for this periodic cleaning will depend, of course, upon the conditions in which the projector is operating. Suitable instruments for performing this type of maintenance are a brush and a common vacuum cleaner or an air compressor.

12.2. Periodic maintenance

Lamp

The lamp should be replaced if there is any observable damage or deformation due to heat. This will avoid the danger of the lamp exploding.

Mechanicals

Periodically check all mechanical devices for wear and tear; gears, guides, belts, etc., replacing them if necessary. Periodically check the lubrication of all components, particularly the parts subject to high temperatures. If necessary, lubricate with suitable lubricant, available from your **Coemar** distributor.

Electrical components

Check all electrical components for correct earthing and proper attachment of all connectors, refastening if necessary.

12.3. Fuse replacement

Locate the fuse, which protects the lamp and electronics, in the base of the **miniCYC MB**.

Using a multimeter, test the condition of the fuse, replacing it with one of equivalent type if necessary.

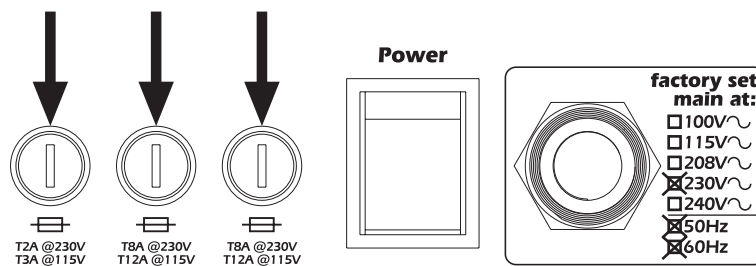

12.4. Electronic motor alignment

ATTENTION!!

This procedure should only be undertaken by qualified and experienced technical personnel..

The display panel of the **miniCYC MB** allows for the electronic alignment of the projector's motors in the optical system. This procedure is performed by **Coemar** at the factory. It may be useful to perform this procedure in the case of internal components being replaced (motors, electronic parts, sensor, ecc.).

Altering the factory settings may radically alter the functioning of the projector. Carefully read all of the following prior to attempting any changes.

Electronic calibration

ATTENTION!!

The alignment procedure can only be carried out when DMX 512 signal is connected.

1. Press the **menu** button and then **enter** to confirm.
2. Press the **+** or **-** button until **FUNC** is displayed. Then press **enter**.
3. Press the **+** or **-** button until **RESE** is displayed.
4. Press the **enter** and **menu** buttons simultaneously, holding them for at least **10"**. The motors will perform a reset and the display will show **----** for a few seconds. After this, the display will show **ALIG** confirming that you have entered electronic calibration mode.



Note: Simultaneously pressing the **+** and **-** buttons will return the calibration value to 128 (default).

English

12.5. Resetting the counter

The lamp life counter needs to be reset to zero at every lamp change to provide accurate information on lamp life. To do this you will need to access the calibration menu (see section **11.4 Electronic motor alignment**). The following are the required steps:

1. Press the **menu** button.
2. Press the **+** or **-** buttons until **FUNC** is displayed. Confirm this by pressing **enter**.
3. Press the **+** or **-** buttons until **RESE** is displayed.
4. Press the **menu** and **enter** buttons simultaneously, holding them pressed for about 10 seconds. The unit's motors will perform a reset and the display will show **----** for a few seconds. At the end of this, the display will show **ALIG** confirming you have entered calibration mode.
5. Press the **+** or **-** buttons until **C.LAM** is displayed. Confirm this by pressing **enter**.
6. Press the **+** or **-** buttons until **RIGH** is displayed (to access the lamp life counter for the right lamp) and press **enter**.
7. The display will show **SURE**. Confirm this by pressing **enter**.
8. Press the **+** or **-** buttons until **LEFT** is displayed (to access the lamp life counter for the left lamp) and press **enter**.
9. The display will show **SURE**. Confirm this by pressing **enter**.
10. To exit calibration mode, press the **+** or **-** button until **END** is displayed. Confirm this by pressing **enter**.

N.B. In the **HOUR** section of the **MEAS** menu, you may confirm that the **LIFE** values have been reset, whilst the other measures **LIFS** (total lamp life) and **UNIT** (projector life) remain unaltered.

12.6. Software upload

By this function it is possible to update the software (main and display) of **miniCYC MB**.

1. Press the **menu** button.
2. Press the **+** or **-** buttons until **FUNC** is displayed. Confirm this by pressing **enter**.
3. Press the **+** or **-** buttons until **RESE** is displayed.
4. Press the **menu** and **enter** buttons simultaneously, holding them pressed for about 10 seconds. The unit's motors will perform a reset and the display will show **----** for a few seconds. At the end of this, the display will show **ALIG** confirming you have entered calibration mode.
5. Press the **+** or **-** buttons until **UPLD** is displayed. Confirm this by pressing **enter**.
6. Press the **+** or **-** buttons until **MIC.D** is displayed (to upload the display software) or **MIC.M** (to upload the main software). Confirm this by pressing **enter**.
7. The display will show **SURE**. Confirm this by pressing **enter**.
The projector will wait for the data coming from the DR1 for one minute (it will be shown a countdown of 60 sec)
If it doesn't receive any data it will go out of the function automatically starting the RESET of the unit.
If you start up the UPLOAD of DR1 (see the DR1 user manual) it will be displayed a software updating and at the end it will go out of the function starting the RESET of the unit.

12.7. Software download

By this function it is possible to download a copy of the software (main and display) of **miniCYC MB** to **DR1**.

1. Press the **menu** button.
2. Press the **+** or **-** buttons until **FUNC** is displayed. Confirm this by pressing **enter**.
3. Press the **+** or **-** buttons until **RESE** is displayed.
4. Press the **menu** and **enter** buttons simultaneously, holding them pressed for about 10 seconds. The unit's motors will perform a reset and the display will show **----** for a few seconds. At the end of this, the display will show **ALIG** confirming you have entered calibration mode.
5. Press the **+** or **-** buttons until **DULD** is displayed. Confirm this by pressing **enter**.
6. Press the **+** or **-** buttons until **MIC.D** is displayed (to download the display software) or **MIC.M** (to download the main software). Confirm this by pressing **enter**.
7. The display will show **SURE**. Confirm this by pressing **enter**.
The projector will wait for the data coming to the DR1 for one minute (it will be shown a countdown of 60 sec)
If it doesn't download any data it will go out of the function automatically starting the RESET of the unit.
If you start up the DOWNLOAD of DR1 (see the DR1 user manual) it will be displayed a software downloading and at the end it will go out of the function starting the RESET of the unit.

13. Spare parts

All the components of the **miniCYC MB** are available as replacement spares from your authorised **Coemar** service centre. Accurate description of the fixture, model number, and type will assist us in providing for your requirements in an efficient and effective manner.

14. Accessory

In the table below are listed all the accessory of the **miniCYC MB** and the related **Coemar** code.

Descrizione	Codice
1. Maximum diffusion kit	9832
2. 4 leaf barndoor	9829

15. Patents

miniCYC MB is protected by various international patents which prohibit copying of the unit in total or in part.

16. Error messages

OPER:	PAN ENCODER Error This message indicates that there is a problem with the PAN encoders. Check the sensors on the encoder wheel located near the pan movement motor, as well as the relevant cabling.
OTER:	TILT ENCODER Error This message indicates that there is a problem with the TILT encoder locate on the fixture yoke. Check the sensors on the encoder wheel located near the pan movement motor, as well as the relevant cabling.
SNER:	SYNCHRONISM Error The projector took a net frequency out of the admitted range and this does not enables the lamp controlled by the mechanical relay to switch on to avoid problems to the control pcb.
OTER:	DATA Error The initial parameter settings are incorrect or corrupt; the projector has reloaded its factory default settings. Turn the projector off and on again. Should the error reoccur, refer the unit to your authorised Coemar service centre to have the EEPROM check and possibly replaced.
ADER:	DMX ADDRESS Error The projector is not receiving all DMX channels needed to operate correctly. Check the DMX address indicated on the display and the channel numbers being outputted from the controller. Note that not all controllers will output all 512 channels.
ER20÷ER99:	SYSTEM Error Turn the unit off and on again. If the error persists, contact your authorised Coemar service centre.

17. Frequently asked questions

Question	Possible cause	Possible solution
The projector is completely immobile.	Projector not powered up. The circuit breaker is switched off The protection fuse is blown	Check that the mains power cable is connected to power. Set the circuit breaker to ON. Disconnect the projector and replace the fuse.
The projector resets correctly, but either does not respond, or responds incorrectly, to DMX signal.	Incorrect signal connection Incorrect DMX address	Inspect the signal cable, rectify any incorrect wiring, repair or replace any damaged cables or connectors. Check the DMX address.
The lamp turns off intermittently	The projector is too hot.	Let the fixture cool down. Check that the air vents above the cooling fans are not obstructed and that the fans are working correctly. Ensure that the ambient temperature is below 35 °C. One of the fans does not work correctly and causes the overheating of the projector.



Coemar s.p.a.

via Inghilterra 2/A - 46042 Castel Goffredo (Mantova) Italy
ph. +39 0376/77521 - fax +39 0376/780657
info@coemar.com

Coemar si riserva il diritto di apportare modifiche senza preavviso.
Coemar reserves the right to effect modifications without notification