

DX32 Technical Datasheet

Overview

- dLive modular Expander
- 4x slots, up to 32ch
- Any combination of analogue / digital I/O modules
- New preamp design for extra transparency
- Unique Active PAD circuit for consistent performance with any source
- Redundant Cat5 connection to dLive MixRack or Surface
- Dual redundant, hot swappable power supply
- Can be rack-mounted or used on stage floor

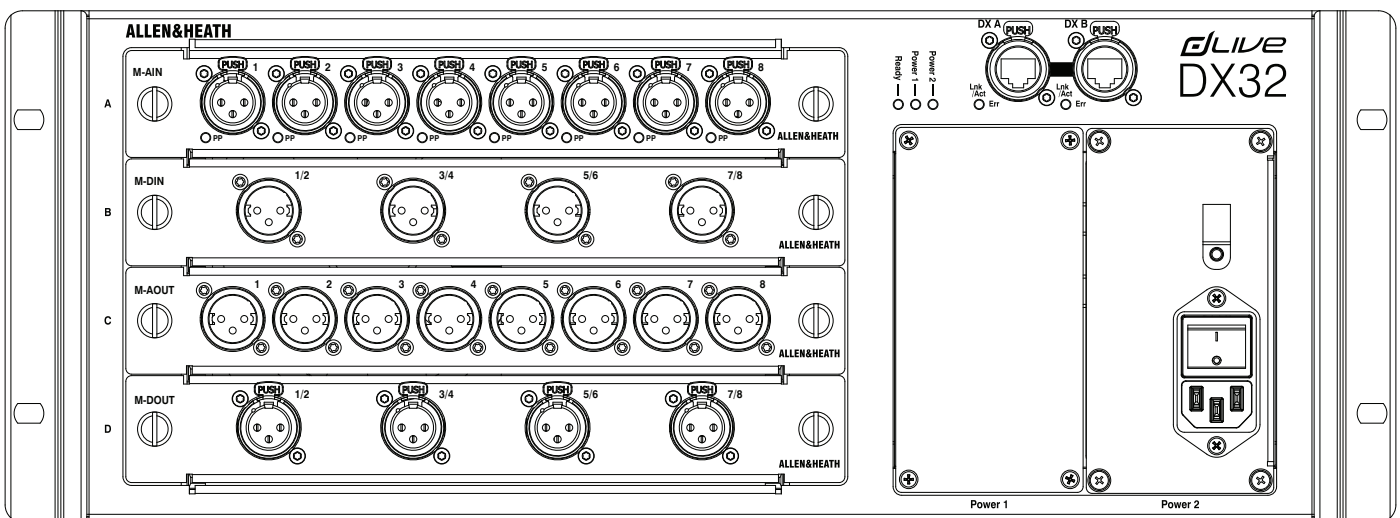

A&E Specifications

The expander shall be rack-mountable and shall include plastic feet for shelf or floor operation. It shall provide 4 slots to fit any combination of analogue or digital 8-channel I/O modules.

A pair of Ethercon ports shall be provided for redundant connection to the control surface or mix engine over Fast Ethernet. This connection shall carry up to 32x32 channels of uncompressed audio at 96kHz and control data. It shall also provide automatic firmware update to the expander at power up of the system when a firmware mismatch is detected.

Available I/O modules shall include:

- 8 recallable preamps with XLR connectors for balanced or unbalanced microphone and line level signals. Gain, Pad and 48V shall be digitally controlled within the preamp. A phantom power indicator shall be provided.

- 8 line level, balanced XLR outputs. The outputs shall be relay protected to prevent power on or off thumps.
- 4x stereo AES3 inputs on XLR with SRC (32kHz – 192kHz sampling rate). It shall be possible to bypass Sample Rate Conversion for each socket.
- 4x stereo AES3 outputs on XLR (44.1kHz, 48kHz or 96kHz switchable).

The unit shall have a modular power supply accepting AC mains voltages of 100~240V, 50/60 Hz, 300W max via an earthed 3-pin IEC male connector. A rocker switch shall be provided near the mains inlet to isolate the mixer from the incoming mains supply. The unit shall also provide the option for a second, hot-swappable, redundant power supply. This shall be of the same type and interchangeable with the power supply fitted as standard.

The expander shall be the Allen&Heath dLive DX32.

Dimensions

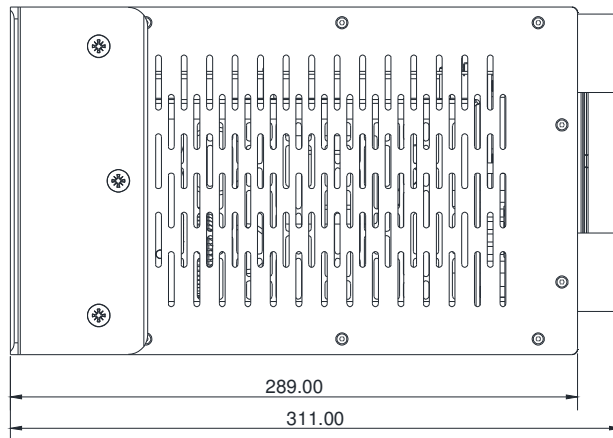
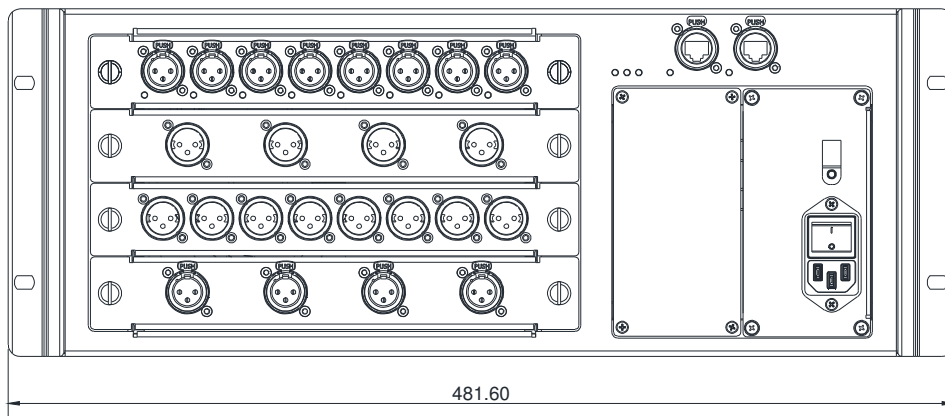
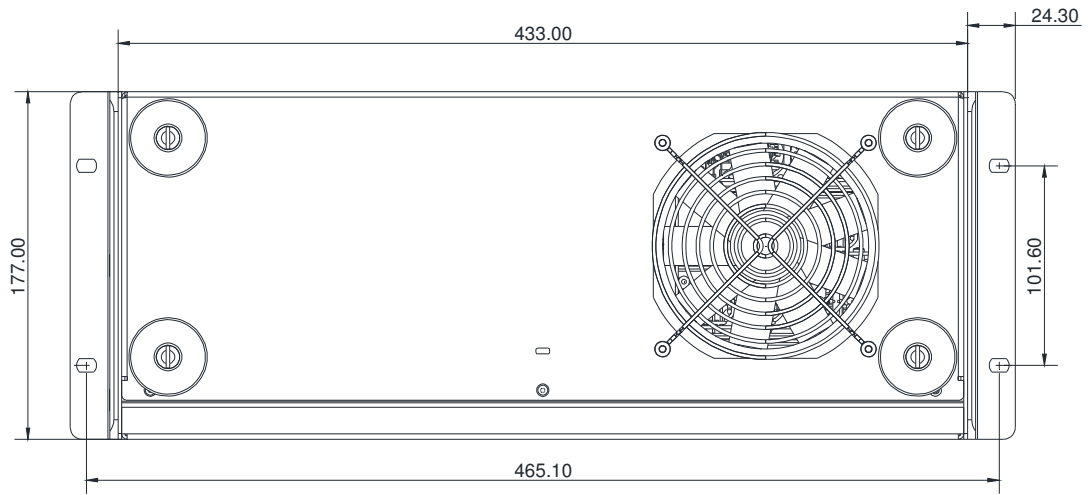

Technical Specifications

Inputs

Mic/Line XLR Inputs	Balanced XLR, +48V phantom power
Mic/Line Preamp	Fully recallable
Input Sensitivity	-60 to +15dBu
Analogue Gain	+5 to +60dB, 1dB steps
Pad	-20dB Active PAD
Maximum Input Level	+30dBu (PAD in)
Input Impedance	>4k Ω (Pad out), >10k Ω (Pad in)
Mic EIN	-127dB with 150 Ω source
Phantom Power indication	Per socket, internal or external phantom power sensing, triggered at 24V

Digital Inputs	AES3 2 Ch XLR, 2.5Vpp balanced terminated 110 Ω SRC on each pair, range 32k - 192kHz, with bypass option
-----------------------	--

Outputs

Analogue XLR Outputs	Balanced, Relay protected
Output Impedance	<75 Ω
Nominal Output	+4dBu = 0dB meter reading
Maximum Output Level	+22dBu
Residual Output Noise	-92dBu (muted, 20-20kHz) -90dBu (muted, 20-40kHz)
Digital Outputs	AES3 2 Ch XLR, 2.5Vpp balanced terminated 110 Ω 96kHz sampling rate, switchable to 48kHz, 44.1kHz

System

Sampling Rate	
ADC	24-bit Delta-Sigma
DAC	24-bit Delta-Sigma
Latency	+ 8 samples, DX32 to Mixrack or DX32 to Surface (DX hop)
System latency	0.7 ms (MixRack XLR in to XLR out, Input to Mix) + 5 samples, Surface to Mixrack (GigaACE hop)
Operating Temperature Range	0 deg C to 35 deg C (32 deg F to 95 deg F)
Mains Power (MPS16)	100-240V AC, 47-63Hz, 300W max

Dimensions and Weights

Width x Depth x Height x Weight	
DX32	433 x 290 x 177 mm x 10.5kg (23lbs)